



REQUEST FOR PROPOSAL

**Air Conditioning Technology Building Renovation
Waco Campus**

RFP-19-PG-003

NIGP Class Code(s): 909-60, 909-66

**RESPONSES ARE DUE BEFORE:
Monday, June 10, 2019, 2:00 PM CST**

POINT OF CONTACT:
Pedro Guardiola, CTCD
Texas State Technical College
Phone: (956)364-4428
Pedro.guardiola@tstc.edu

TABLE OF CONTENTS

SECTION 1:	GENERAL INFORMATION
SECTION 2:	SCOPE OF WORK
SECTION 3:	PROPOSAL REQUIREMENTS
SECTION 4:	EVALUATION
SECTION 5:	CONTRACT
SECTION 6:	FORMS
FORM A:	Execution of Offer
FORM B:	DEVIATION/COMPLIANCE SIGNATURE FORM
FORM C:	NON-COLLUSION STATEMENT
FORM D:	REFERENCES
FORM E:	INTERLOCAL AGREEMENT CLAUSE
FORM F:	HUB Subcontracting Plan (Submit if Proposers Bid Response is over \$100,000)
FORM G:	No Bid Response (Optional)
FORM H:	PROPOSAL FORM
SECTION 7:	MISCELLANEOUS (Drawings, attachments, etc.)
	ATTACHMENT A – ACT PBE Renovation – Complete Plan Set
	ATTACHMENT B - Work Schedule TSTC Waco PDE Renovations ACT

SECTION 1: GENERAL INFORMATION

1.1 Background of Texas State Technical College

Texas State Technical College (“TSTC” or “College”) a state-supported two-year technical college and is the state’s largest provider of technical education. TSTC was originally established in 1965 as the James Connally Technical Institute (JCTI), a two year college in the Texas A&M University System designed to meet the state’s evolving workforce needs. In 1969, the State of Texas gained ownership of James Connally Air Force Base and renamed the college Texas State Technical Institute (TSTI), which became a separate state agency with its own Board of Regents, appointed by the governor. TSTC has been accredited by the Southern Association of Colleges and Schools Commission on Colleges (SACS-COC) as a Level I institution since 1968. The College is an open enrollment institution with a full-time equivalent enrollment of approximately 12,000. In contrast with Texas’s regionally-focused community colleges, TSTC has a statewide role and mission with a legislative mandate to focus specifically on highly specialized, advanced, and emerging technical and vocational areas leading to certificates or associate degrees.

In 2015, the College was granted single-accreditation status from SACS-COC, the regional body for the accreditation of degree-granting higher education institutions in the Southern states. TSTC central administration is located in Waco, Texas, the site of the flagship campus. The College services students throughout the state of Texas at campuses located in Abilene, Breckenridge, Brownwood, Fort Bend County, Harlingen, Marshall, North Texas (Red Oak), Sweetwater, Waco, and Williamson County.

1.2 Purpose of the Request for Proposals

Texas State Technical College (TSTC) (“Owner”) is soliciting statements of proposals (“Proposals”) for renovations to the Air Conditioning Technology building. This will consist of demo of various walls and electrical components, construction of one office, installation of ceiling tiles and grid, installation of lighting fixtures, and painting. The area to be renovated is approx. 14,000 SFT. The Proposer is to supply all material, supervision and labor required to perform the service.

1.3 Submission of Proposal

Pursuant to *Texas Government Code Title 10, Subtitle D, Chapter 2156.121-2158.127*, sealed proposals will be received until the date and time established as the submittal deadline. After the submittal deadline, proposals will be opened and only the names of Respondents that properly submitted a Proposal will be made public. Prices and other proposal details will only be divulged after the contract award, if one is made.

Proposals must be received before the hour and date specified as the submittal deadline. Any proposal received after the expiration of the submittal deadline will be immediately disqualified from consideration. Proposals will not be accepted by telephone, fax, or email. Proposals will only be accepted at the address below:

**Doris Turner
Texas State Technical College
Patterson Hall
Procurement Office RM#262
3801 Campus Dr.
Waco, Texas 76705
Doris.turner@tstc.edu**

OR

**Pedro Guardiola
Texas State Technical College
Service Support Center
Procurement Office
1902 N. Loop 499
Harlingen, Texas 78550
Phone: 956.364.4428
Pedro.guardiola@tstc.edu**

Submit one (1) original signed proposal and one (1) identical electronic copy of the original signed proposal including all of its contents (“Proposal”). The original Proposal should contain the mark “original” on the Proposal Cover Page. The electronic copy shall be submitted in a USB/Flash Drive or CD in the same envelope as the hard-copy original proposal.

Proposal must be enclosed in a sealed envelope (box or container) addressed as described above. The envelope must clearly identify the RFP number, submittal deadline, and the name and return address of the Respondent. Proposal and any other information submitted by a Respondent in response to this RFP shall become the property of TSTC and will not be returned.

TSTC will not provide “delivery or hand stamp” receipt of Proposal or proof of delivery of Proposal which are delivered by hand or courier.

Failure to comply with all requirements contained in this RFP may result in the rejection of the Proposal. Proposals that are qualified with conditional clauses, alterations, items not called for in the RFP, or irregularities of any kind are subject to rejection.

By submitting a Proposal in response to this RFP, Respondent acknowledges and accepts the evaluation process and that determination of the “best value” will require subjective judgments by TSTC.

1.4 Questions and Clarifications

All questions and clarifications regarding this RFP must be submitted in writing to Pedro Guardiola, at pedro.guardiola@tstc.edu no later than **Thursday, May 30, 2018, 10:00 AM CST**. TSTC reserves the right to request clarification of any information contained in a proposal. Any clarifications or interpretations of this RFP that materially affect or change its requirements will be issued by TSTC as an Addendum. All such Addenda will be issued by TSTC before the submittal deadline as part of the RFP and Respondents shall acknowledge receipt of each Addendum to the RFP in proposal submission.

1.5 Schedule of Events

Issuance of RFP	Friday, May 17, 2019
Pre-Submittal Conference (non-mandatory) Location: TSTC Waco Physical Plant Conference Room #138 1200 Greenway, Waco TX. 76705	Wednesday, May 22, 2019, 10:00 AM CST
Deadline for Written Questions	Thursday, May 30, 2019, 10:00 AM CST
Issuance of Addendum (if necessary)	Monday, June 03, 2019, 5:00 PM CST
Submittal Deadline	Monday, June 10, 2019, 2:00 PM CST
Evaluation and Selection Period (tentative)	Tuesday, June 11, 2019 – Monday, June 17, 2019
Interviews and Negotiations (optional)	TBA
Award/Issuance of Purchase Order (tentative)	Thursday, June 20, 2019

1.6 PRE-SUBMITTAL CONFERENCE:

There will be a pre-conference conducted on Wednesday May 22, 2019 @ 10:00 A.M. CST for RFP-19-PG-003 Air Conditioning Technology Building Renovation.

Pre-Submittal Conference (non-mandatory)
Location: TSTC Waco Physical Plant
Conference Room #138
1200 Greenway, Waco TX. 76705

1.7 Historically Underutilized Business Submittal Requirements

It is the policy of TSTC to promote full and equal opportunities for the contracting and subcontracting of Historically Underutilized Businesses (HUB) in accordance with *Texas Government Code*, Chapter 2161. This Chapter applies to all contracts for the purchase of goods and/or services with an expected value of \$100,000 or more.

A HUB Subcontracting Plan Form (Included as Separate Attachment) must be filled out and returned with the Proposal to be considered responsive. If the Proposal does not include a HUB Subcontracting Plan, it shall be rejected as a material failure to comply with advertised specifications.

Search the State of Texas HUB Database for HUB vendors by the NIGP class and item at: <https://mycpa.cpa.state.tx.us/tpasscmblsearch/index.jsp>

Additional minority and women owned business association resources are available for subcontracting notices at: <http://comptroller.texas.gov/procurement/prog/hub/mwb-links-1/>

Additional information and training regarding how to complete a HUB Sub-Contracting Plan can be found on the CPA Website at the following link: <http://comptroller.texas.gov/procurement/prog/hub/hub-subcontracting-plan/>

1.8 Subcontracting Approval

The Respondent shall perform the Contract with its own resources and those subcontractors identified in the Respondent's HUB Subcontracting Plan. In the event that the Respondent should determine that it is necessary or expedient to execute additional or alternative subcontracts for any of the performances under the Contract, the Respondent shall submit a revised HUB Subcontracting Plan for prior approval before executing any subcontracts.

In any subcontracts entered into by Contractor for the performance of the work, Contractor shall require the Subcontractor, to the extent of the work to be performed by the Subcontractor, to be bound to Contractor by the terms of the contract between Contractor and TSTC and to assume toward Contractor all of the obligations and responsibilities that Contractor, by the contract between Contractor and TSTC, assumes toward TSTC.

The Respondent shall manage all quality and performance, project management, and schedules for subcontractors. The Respondent shall be held solely responsible and accountable for the completion of all work for which the Respondent has subcontracted.

1.9 Proposal Requirements

Proposals cannot be altered after the proposal submittal deadline and must be firm for up to 90 days from the submittal deadline. Proposals cannot be withdrawn after submittal deadline without written approval by TSTC based on a written request to withdraw.

1.10 Signature, Certification of Proposer

Proposals submitted without the required forms and authorized signatures, as specified in Section 3(Proposal Requirements) and Section 6(Attachments) are subject to disqualification at TSTC's sole discretion.

1.11 Proposal Evaluation and Award Process

Proposals will be evaluated in accordance with Section 4.1 of the RFP.

1.12 Exceptions to RFP

Any exceptions to terms, conditions, and requirements of the RFP, including the Service Agreement, must be made in writing and noted in the Proposal. Please refer to Section 6, Form B for the required form.

1.13 No Reimbursement for Proposal Costs

TSTC specifically disclaims the responsibility and/or liability for all costs, expenses, or claims related to or arising out of the proposers' participation in this RFP process, including but not limited to costs incurred as a result of preparing, copying, shipping, presenting, and/or clarifying their Proposal and the information relevant to the Proposal. Proposers acknowledge and accept that any costs incurred from proposers' participation in this RFP process shall be at their sole risk and responsibility.

1.14 Taxes

As an institute of higher education and agency of the State of Texas, TSTC is exempt from payment of Texas state and local sales or use taxes on all purchases (*Texas Tax Code, Section 151.309*). Do not include sales tax in Proposal. Tax exemption certificates are available upon request.

1.15 Reservation of Rights

TSTC reserves the right to modify the RFP, divide the Scope of Work into multiple parts, and reject any and all proposals to re-solicit for new proposals or temporarily or permanently abandon the RFP prior to the date on which TSTC's delegated authority executes a contract with the selected Proposer.

1.16 Texas Public Information Act

Proposers acknowledge that TSTC is an agency of the State of Texas, and is therefore required to comply with the Texas Public Information Act (*Texas Government Code, Chapter 552.001, et seq.*) TSTC strictly complies with all statutes, court decisions, and opinions of the Texas Attorney General with respect to disclosure of public information. All information, documentation, and other materials submitted in response to this RFP are considered non-confidential and/or non-proprietary and are subject to public disclosure. If proposals include proprietary data, trade secrets, or information proposers must specifically label such data, secrets, or information as follows: **“PRIVILEGED AND CONFIDENTIAL – PROPRIETARY INFORMATION”**.

1.17 Equal Opportunity

Proposer must be an equal opportunity employer. No person shall be discriminated against in employment because of race, color, religion, gender, national origin, disability, or age.

1.18 Accuracy of Information

The information presented in this RFP is complete and accurate to the best of TSTC’s knowledge. If proposers have any questions in regards to this RFP, a written request should be submitted to Point of Contact before the Deadline for Written Questions specified herein.

1.19 Contract Award

Proposals to this RFP are offers to contract with TSTC. Proposals do not become contracts and are not binding until a written contract is executed by TSTC’s delegated authority and awarded Proposer. Awarded Proposal will become incorporated by reference in the written contract. TSTC shall reserve the right to award a contract for part or all requirements in the RFP, to award multiple awards, or not award any contract, according to what is in the best interest of the TSTC.

1.20 Ethics Conduct

Any direct or indirect actions taken to unduly influence competitive purposes, to circumvent equal consideration for competitive bidders, or to disregard ethical and legal trade practices will disqualify proposers from current and future consideration for participation in TSTC purchase orders and contracts.

SECTION 2: SCOPE OF WORK

2.1 Overview

TSTC is soliciting proposals for renovations to the Air Conditioning Technology building. This will consist of demo of various walls and electrical components, construction of one office, installation of ceiling tiles and grid, installation of lighting fixtures, and painting. The area to be renovated is approx. 14,000 SFT. The current ACT lab area is not adequate for the Performance Based Education that TSTC is wanting implemented. This renovation will bring the building to a design that will work for PBE. This renovation will not affect any other departments.

2.2 GENERAL NOTES

This building must have lighting on each day the schedule shows student activity. It is permissible with TSTC to leave the existing light fixtures in place while work is ongoing (installing tile grid-etc.). Contractor has the option to leave existing light fixture in place permanently for this process but the existing bulbs must be removed before completion of project.

2.3 SCOPE OF WORK:

2.3.1 ROOM 107:

1. Cut and demo area of CMU wall as needed for four 5'x6' glass window panels with aluminum frames.
2. Install 4" channel iron inside perimeter of openings. This channel iron will be used for support. The aluminum framed glass panels will set in this metal framework.
3. Install glass window panels
4. Trainers will be turned 180 degrees by TSTC and must have electrical power. See plans.
5. Relocate electrical for trainers inside room.
6. Relocate two junction boxes on North wall to just below ceiling height in order to accommodate for new windows.
7. Contractor to use existing electrical panels with breakers to power trainers.
8. Remove the nine existing light fixtures and replace with new 3 lamp, 2'x4' static lensed troffer, electronic ballast light fixtures with 15W LED T8 5K ballasted bulbs.
9. Install new 3'0"x7'0" 1 3/4", single bore, prefinished Maple wood door in existing door jamb. Door to have approx. 4"x34" glass panel.
10. Door locks to be ARROW –MLX81 with 26D finish. This is an ADA in a satin chrome finish. TSTC to furnish Medico cylinders.
11. Paint walls and trim with Sherwin Williams Promar 200, walls to be satin and trim to be semi-gloss. Color to be determined later.

2.3.2 ROOM 108:

1. Cut and demo area of CMU wall as needed for four 5'x6' glass window panels with aluminum frames.
2. Install 4" channel iron inside perimeter of openings. This channel iron will be used for support. The aluminum framed glass panels will set in the metal framework.
3. Install glass window panels.
4. Remove 5 electrical duplex outlets and 2-three gang light switches with plates. Replace these with new.
5. Remove the nine existing light fixtures and replace with new 3 lamp, 2'x4' static lensed troffer, electronic ballast light fixtures with 15W LED T8 5K ballasted bulbs.
6. Demo 8"x8' plywood hangar board and patch holes.
7. Repair approx. 1 SQFT. of plaster.
8. Install new 3'0"x7'0" 1 3/4", single bore, prefinished Maple wood door in existing door jamb. Door to have approx. 4"x34" glass panel.
9. Door locks to be ARROW –MLX81 with 26D finish. This is an ADA in a satin chrome finish. TSTC to furnish Medico cylinder.
10. Paint walls, door, and trim with Sherwin Williams Promar 200, walls to be satin and trim to be semi-gloss. Color to be determined later.

2.3.3 ROOM 101B:

1. Replace fire rated doors on each end of this hall.
2. Install new Sargent door closures on these doors.
3. These fire door Mag-locks must be working properly.
4. Paint walls and trim with Sherwin Williams Promar 200, walls to be satin and trim to be semi-gloss. Color to be determined later.

2.3.4 ROOM 109:

1. Demo existing light fixtures.
2. Demo all electrical marked.
3. Demo walls as shown on plans.
4. Install 3"-4" tube running from floor to just above new ceiling height at panel set on top of wooden trainers inside the East side of the room and as shown on plans. This panel is the source for these trainers. The feed for this panel is located on the East wall of room 109B and this is shown on plans as well. Relocate this feed from existing panel using the tube conduit that is to be installed and back to the feeder panel.
5. Relocate 5 electrical duplex with plates along with EMT on North side of room and as shown on plans. The panel for these are just inside the wall separating rooms 190 and 109RF. The new outlets are to be installed on the West side of room 109.
6. These outlets will have one single 20 AMP service for each outlet.
7. Install a new 1" schedule 40 PVC pipe for icemakers that will be installed in this area. Pipe shall be ditched just outside of building and penetrate building where icemakers are installed. The distance of the pipe is approx. 80 LFT. Install ball valve and valve box within 6' of where the new line is tied into the main. Install a ball valve just inside of building. The main is a 4" PVC pipe that was install less than a year ago.

8. Install new 2'x2' ceiling grid and ceiling tiles, USG RADAR R2110 2'x2' just above bus ducts.
9. Install new LED light fixtures -3 lamp, 2'x4' static lensed troffer, electronic ballast light fixtures with 15W LED T8 5K ballasted bulbs. See plans for count and location.
10. Repair approx. 10 SQFT of plaster around man door on South side.
11. Paint walls, door, and trim with Sherwin Williams Promar 200, walls to be satin and trim to be semi-gloss. Color to be determined later

2.3.5 ROOM 109A:

1. NOT IN SCOPE OF WORK

2.3.6 ROOM 109BW:

1. Demo wooden stairs back to wall. Frame this void in using wood up to 9'8". Install Masonite siding to match existing. Trim to match.
2. Existing Masonite on this wall has bowed out. Install 2x4 blocking from inside room 109A (it is open studded wall form inside) and nail the bowed area back in to meet the existing studs.
3. Demo marked electrical.
4. Demo existing light fixtures.
5. Demo walls as shown on plans.
6. Install new 2'x2' ceiling grid and ceiling tiles, USG RADAR R2110 2'x2' just above existing bus ducts.
7. Install new LED light fixtures -3 lamp, 2'x4' static lensed troffer, electronic ballast light fixtures with 15W LED T8 5K ballasted bulbs. See plans for count and location.
8. Paint walls, door, and trim with Sherwin Williams Promar 200, walls to be satin and trim to be semi-gloss. Color to be determined later

2.3.7 ROOM 109B:

1. Demo approx. 55 LFT of overhead metal HVAC duct back to East wall.
2. Demo existing light fixtures.
3. Demo all marked electrical.
4. Demo walls as shown on plans.
5. Install new 2'x2' ceiling grid and ceiling tiles, USG RADAR R2110 2'x2' just above bus ducts.
6. Install new LED light fixtures -3 lamp, 2'x4' static lensed troffer, electronic ballast light fixtures with 15W LED T8 5K ballasted bulbs. See plans for count and location.
7. Paint walls, door, and trim with Sherwin Williams Promar 200, walls to be satin and trim to be semi-gloss. Color to be determined later

2.3.8 ROOM 101C:

1. Demo walls per plans.
2. Relocate the 5 light switches located on the North wall to East wall of room 109B.
3. Demo existing light fixtures.
4. Install new 2'x2' ceiling grid and ceiling tiles, USG RADAR R2110 2'x2' just above bus ducts.
5. Install new LED light fixtures -3 lamp, 2'x4' static lensed troffer, electronic ballast light fixtures with 15W LED T8 5K ballasted bulbs. See plans for count and location.
6. Paint walls, door, and trim with Sherwin Williams Promar 200, walls to be satin and trim to be semi-gloss. Color to be determined later

2.3.9 ROOM 109C:

1. Demo walls per plans.
2. Demo all electrical marked.
3. Demo existing light fixtures.
4. Install new 2'x2' ceiling grid and ceiling tiles, USG RADAR R2110 2'x2' just above bus ducts.
5. Install new LED light fixtures -3 lamp, 2'x4' static lensed troffer, electronic ballast light fixtures with 15W LED T8 5K ballasted bulbs. See plans for count and location.
6. Paint walls, door, and trim with Sherwin Williams Promar 200, walls to be satin and trim to be semi-gloss. Color to be determined later

2.3.10 ROOM 109DW:

1. Demo walls per plans.
2. Demo all electrical marked.
3. Demo existing light fixtures.
4. Install new 2'x2' ceiling grid and ceiling tiles, USG RADAR R2110 2'x2' just above bus ducts.
5. Install new LED light fixtures -3 lamp, 2'x4' static lensed troffer, electronic ballast light fixtures with 15W LED T8 5K ballasted bulbs. See plans for count and location.
6. Paint walls, door, and trim with Sherwin Williams Promar 200, walls to be satin and trim to be semi-gloss. Color to be determined later

2.3.11 ROOM 109RF:

1. Demo walls per plans.
2. Demo all electrical marked.
3. Demo existing light fixtures.
4. Install 7/16" OSB decking on wood framed structure from West wall on top of rafter down 4'.
5. Install 2' tall pony wall on top of newly installed OSB and full distance of the roof of wooden structure.
6. Install 7/16" OSB on the new pony wall. This will serve as a wall to let the new ceiling tile die into.

7. Install new 2'x2' ceiling grid and ceiling tiles, USG RADAR R2110 2'x2'.
8. Install new LED light fixtures -3 lamp, 2'x4' static lensed troffer, electronic ballast light fixtures with 15W LED T8 5K ballasted bulbs. See plans for count and location.
9. Paint walls, door, and trim with Sherwin Williams Promar 200, walls to be satin and trim to be semi-gloss. Color to be determined later

2.3.12 ROOM 110:

1. Demo walls per plans.
2. Demo all electrical marked.
3. Demo existing light fixtures.
4. Demo the 20 electrical drops for the trainers in this room.
5. Relocate one electrical drop to accommodate addition of new office "Room 110S".
6. Install new SO chord the same wire size as the 20 drops just removed used to power the trainers in this room. Install new boxes, duplex, and plates on the new SO chords.
7. Install metal purlins and columns for the steel mezzanine as shown on plans.
8. Install new 2'x2' ceiling grid and ceiling tiles, USG RADAR R2110 2'x2'.
9. Install new LED light fixtures -3 lamp, 2'x4' static lensed troffer, electronic ballast light fixtures with 15W LED T8 5K ballasted bulbs. See plans for count and location.
10. Paint walls, door, and trim with Sherwin Williams Promar 200, walls to be satin and trim to be semi-gloss. Color to be determined later

2.3.13 ROOM 110 A & B:

1. Install 6" metal purlin to interior 6" purlin of metal mezzanine forming a truss. This is required to eliminate the cable hangar used to hold this mezzanine in place. See plans.
2. Install 2-10" C purlins (welded together" from mezzanine to West wall of 110A. This purlin will be set 2' above the southwest corner of the mezzanine on a 4" metal tube that is mounted on the top of the mezzanine. See plans.
3. Install 4" metal tube column below the southwest corner of mezzanine and anchor to the floor. See Plans.
4. Demo walls per plans.
5. Demo all electrical marked.
6. Demo existing light fixtures.
7. Demo the two sets of wood doors and jambs and install wood cased openings.
8. Trim out unfinished end of short wall with ¾" smooth wood.
9. Install new 2'x2' ceiling grid and ceiling tiles, USG RADAR R2110 2'x2' .
10. Install new LED light fixtures -3 lamp, 2'x4' static lensed troffer, electronic ballast light fixtures with 15W LED T8 5K ballasted bulbs. See plans for count and location.

11. Paint walls, door, and trim with Sherwin Williams Promar 200, walls to be satin and trim to be semi-gloss. Color to be determined later.

2.3.14 ROOM 112A:

1. Demo walls per plans.
2. Demo all electrical marked.
3. Demo existing light fixtures.
4. Demo plywood panels from walls and replace with 5/8" drywall.
5. Tape, float, and texture new drywall to match existing.
6. Install new 2'x2' ceiling grid and ceiling tiles, USG RADAR R2110 2'x2'.
7. Install new LED light fixtures -3 lamp, 2'x4' static lensed troffer, electronic ballast light fixtures with 15W LED T8 5K ballasted bulbs. See plans for count and location.
8. Paint walls, door, and trim with Sherwin Williams Promar 200, walls to be satin and trim to be semi-gloss. Color to be determined later

2.3.15 ROOM 110D:

1. Demo walls per plans.
2. Demo all electrical marked.
3. Demo existing light fixtures.
4. Relocate 2 disconnects located on wall separating 110D and 110E and install on exterior wall of room 110E.
5. Repair approx. 30 SQFT of plaster.
6. Install new 2'x2' ceiling grid and ceiling tiles, USG RADAR R2110 2'x2'.
7. Install new LED light fixtures -3 lamp, 2'x4' static lensed troffer, electronic ballast light fixtures with 15W LED T8 5K ballasted bulbs. See plans for count and location.
8. Paint walls, door, and trim with Sherwin Williams Promar 200, walls to be satin and trim to be semi-gloss. Color to be determined later

2.3.16 ROOM 110E:

1. Demo walls per plans.
2. Demo all electrical marked.
3. Demo existing light fixtures.
4. Repair approx. 20 SQFT of plaster.
5. Install new 2'x2' ceiling grid and ceiling tiles, USG RADAR R2110 2'x2'.
6. Install new LED light fixtures -3 lamp, 2'x4' static lensed troffer, electronic ballast light fixtures with 15W LED T8 5K ballasted bulbs. See plans for count and location.

7. Paint walls, door, and trim with Sherwin Williams Promar 200, walls to be satin and trim to be semi-gloss. Color to be determined later.

2.3.17 ROOM 110F:

1. Demo walls per plans.
2. Demo all electrical marked.
3. Demo existing light fixtures.
4. Install 2"x2" 26 gauge metal angle on top and bottom of metal purlins. These angles to be as close to center line of purlins as possible. Screw angles to purlins. This will be used to stabilize the purlins.
5. Install 8- light fixtures to bottom of purlins and spaced symmetrically. These fixtures to be KEYSTONE Model # KT-DDSLEDT8-4-2L-CP with KT-LED15T8-48GC-850-DX2 bulbs.
6. Install new 2'x2' ceiling grid and ceiling tiles, USG RADAR R2110 2'x2'.
7. Install new LED light fixtures in ceiling grid -3 lamp, 2'x4' static lensed troffer, electronic ballast light fixtures with 15W LED T8 5K ballasted bulbs. See plans for count and location.
8. Paint walls, door, and trim with Sherwin Williams Promar 200, walls to be satin and trim to be semi-gloss. Color to be determined later

2.3.18 ROOM 110H:

1. Demo walls per plans.
2. Demo all electrical marked.
3. Demo existing light fixtures.
4. Run power for exit light at back door from nearest power source.
5. Install new 2'x2' ceiling grid and ceiling tiles, USG RADAR R2110 2'x2'.
6. Install new LED light fixtures -3 lamp, 2'x4' static lensed troffer, electronic ballast light fixtures with 15W LED T8 5K ballasted bulbs. See plans for count and location.

ROOM 110S:

1. Demo all electrical marked.
2. Demo existing light fixtures in area of new office 110S.
3. Construct 9' wood frame walls per dimension on plans. Walls to have single bottom plate, double top plate, 24" O.C. studs, anchored to floor and existing walls.
4. Install 2x6" ceiling joists on 24" O.C.
5. Install 7/16" OSB on top of joists.
6. Install 5/8" drywall on exterior and interior of new walls, tape, float, and texture.
7. Install 3'0"x7'0" single bore 1 3/4" wood commercial door, pre-finished maple, with approx. 4"x34" glass. Door jamb to be weld up or knock down type.

8. Door locks to be ARROW –MLX81 with 26D finish. This is an ADA in a satin chrome finish. TSTC to furnish Medico cylinders.
9. Install electrical per plans.
10. HVAC- Tap into plenum above ceiling in 111 with an 8” flex duct to supply room 110S. This will require boring a hole in the wall separating the two rooms. This concrete wall is CMU block filled with concrete. This will also require boring through a 3’x3’ plastered furr out on the inside of room 111. This will be shown in the pre-proposal walk through. These holes must be sealed after the ducts are installed.
Install a wood frame, with drywall or plywood sheathing covering to hide the flex duct that will supply HVAC for room 110S. This covering is to be painted.
11. Install a thermostat controlled damper in this line and install the thermostat in room 110S.
12. Install return grill in room 110 S and tap into return flex in room 111.
13. Install ½” EMT and box for data drop at location shown on plan. TSTC will install data cable for this drop.
14. Install 5/8” fire rated drywall, tape, float, texture, and paint on walls.
15. Install new 2’x2’ ceiling grid and ceiling tiles, USG RADAR R2110 2’x2’ at 8’6” ceiling height.
16. Install one LED light fixtures -3 lamp, 2’x4’ static lensed troffer, electronic ballast light fixtures with 15W LED T8 5K ballasted bulbs. See plans.
17. Paint walls and trim with Sherwin Williams Promar 200, walls to be satin and trim to be semi-gloss. Color to be determined later.
18. Install VCT flooring with 4” rubber cove base.

2.4 TSTC Responsibilities:

Provide Drawings For:

2.4.1 ACT Building Drawings

https://drive.google.com/a/tstc.edu/file/d/1TIXksLa_zaNm4z-0y8be7CPnMGIKNDIt/view?usp=sharing

<https://drive.google.com/a/tstc.edu/file/d/1Cy5wdmbYcV60FQCXZBUzOAaJ7GehSwK4/view?usp=sharing>

2.4.2 Develop a Schedule of Values

2.5 Contractor Minimum Responsibilities

- 2.5.1 Maintain License Requirements: License to perform Electrical Work in the State of Texas. License must be provided prior to commencement of work and upon request.
- 2.5.2 Proposer(s) must provide Services between 8:00 AM – 5:00 PM, Monday - Friday unless special arrangements have been made with TSTC Facilities.
- 2.5.3 Proposer shall maintain required insurance as noted in sample contract Section 5.

2.6 Mandatory Requirements/Conditions

- 2.6.1 Proposer(s) must have at least three (3) years of experience in providing Services in a Higher Education setting.
- 2.6.2 Proposer(s) must provide an SDS sheet for all chemicals used on campus.
- 2.6.3 Proposer(s) must provide written documentation to TSTC of each warranty within thirty (30) days after completion of Services.
- 2.6.4 Proposer(s) must provide proof of all required licenses and certifications.
- 2.6.5 Proposer(s) must perform all Services in accordance with the latest edition of the TSTC's Uniform General Conditions.
- 2.6.6 All employees of Proposer(s) performing Services on TSTC properties must wear uniforms or identification badges. No employee of the Proposer will be permitted on TSTC properties without proper identification.
- 2.6.7 Harassment: Under no circumstance will the University tolerate any form of verbal or non-verbal abuse, jeering, whistling, etc. directed toward College staff or students. The Proposer will be informed of any complaints and will be expected to permanently remove the problem employee from the job.
- 2.6.8 Smoking: All tobacco products, including smokeless tobacco, are prohibited on TSTC property at all times. This must be fully enforced by the Proposer.
- 2.6.9 Illegal Drugs and Alcohol: No alcoholic beverages or illegal drugs shall be brought on TSTC property at any time. Any workmen under the influence of either illegal drugs or alcohol or smelling of alcohol shall be permanently removed from the property by the Proposer.
- 2.6.10 Firearms/Weapons: Pursuant to Section 30.07 Penal Code, A person licensed under Subchapter H, Chapter 411, Government Code, may not enter any TSTC premises with a gun that is carried openly.
- 2.6.11 Restrooms: Under no conditions will any of the workmen be allowed to use restrooms within the existing College facilities except for building ACT and they must be kept clean.
- 2.6.12 Proposer(s) must coordinate the execution of Services with TSTC.
- 2.6.13 Proposer(s) must include all costs related to providing the complete Services requested and reference the applicable contract number on all quotes.
- 2.6.14 TSTC will not be responsible for any Materials or Services not specifically detailed on the quote and approved through a formalized TSTC Purchase Order.

2.6.15 Proposer(s) must provide all necessary bonds and permits as required as defined in the UGC.

2.7 Preferred Requirements/Conditions

2.7.1 Proposer(s) should document their green initiative for providing responsible environmental practices.

2.8 Quality Measures

2.8.1 All Materials and Services delivered by Proposer(s) to TSTC are subject to inspection and approval by TSTC.

2.8.2 If for any reason TSTC is not satisfied with the Services, Proposer(s) must coordinate with TSTC to resolve the problem(s) with no additional charge, unless agreed upon in writing by TSTC.

2.9 Contract Administration

Contract Manager for this project Mike Ratliff.

2.10 Change or Addition to Scope of Services

TSTC, without invalidating the contract, may make changes by altering, adding to, or deduction from the Scope of Services at any time during the term of the contract in order to meet current TSTC needs. The Contract pricing shall be adjusted accordingly, upon mutual agreement between TSTC and Contractor.

Should TSTC request additional services during the term of the Contract, an agreement to provide these services at the same price as quoted will be understood as included in the Respondent's submission.

SECTION 3: PROPOSAL REQUIREMENTS

The Proposal must be organized in sections and divided by tabs in the following format and contain the following information. Respondents should note that elaborate or unnecessary voluminous proposals are not desired. All forms must be completed, signed, and returned as part of the Respondent's proposal.

3.1 Execution of Offer (TAB 1)

The Execution of Offer (Form A, Section 6) should be the first page of your Proposal. This form must be signed by a person authorized to sign for the Respondent.

3.2 Proposal Criteria (Each section should be in a separate tab)

Proposal Response (TAB 1)- Respondents to provide a detailed proposal in how the services will be provided. Explain what the Respondent has learned from the drawings and site visit. TSTC is interested in the approach, methods, and customer service that the firm will employ to provide the services. Address Requirements in Section 2.3.

Project's teams' relative experience including sub-contractors and their likely roles (TAB 2) -Identify the key professionals that will be involved with the project. Provide a detailed history of their experience.

Experience on similar higher education projects and experience with TSTC (TAB 3) -List three projects similar in size and scope completed for higher education clients in the past five years. Provide accurate customer contact information for these projects that will give reference for the work performed.

References on previous higher education projects (TAB 4)-Please list contact information. Use Form D in Section 6

Price Form (TAB 5) - Respondents are to submit Form H.

3.3 All Required Forms (Each form should be in a separate tab)

Form A: Execution of Offer [MUST BE SIGNED FOR RESPONSE TO BE ACCEPTED]

Form B: Deviation/Compliance Signature Form

Form C: Non-Collusion Statement

Form D: References

Form E: Inter-Local Agreement

Form F: HUB Sub-Contracting Plan [If proposal is over \$100,000, must be signed]

Form G: Non Bid Response [Optional]

Form H: Price Form

SECTION 4: EVALUATION

Respondent is encouraged to propose terms and conditions offering the maximum benefit to TSTC in terms of (1) services to TSTC, (2) total overall cost to TSTC, and (3) expertise. Respondents should describe all educational, state and local government discounts, as well as any other applicable discounts that may be available to TSTC.

An evaluation team from TSTC will evaluate the Proposal. The evaluation of Proposal and the selection of a respondent will be based on the information provided by Respondent in its Proposal. TSTC may give consideration to additional information if TSTC deems such information relevant.

The criteria to be considered by TSTC in evaluating Proposal and selecting a Contractor will be those factors listed below.

Threshold Criteria Not Scored:

- Ability of TSTC to comply with laws regarding Historically Underutilized Businesses; and
- Ability of TSTC to comply with laws regarding purchases from persons with disabilities

Respondents shall carefully read the information contained in Section 4.1 and submit a complete statement of Proposals to all questions in Section 3.2. Incomplete Proposals will be considered non-responsive and subject to rejection.

Criteria to be Evaluated		Points
Criteria One:	Project teams relative experience including subcontractors	10
Criteria Two:	Experience on similar higher education projects and experience with Texas State Technical College	20
Criteria Three:	References on previous higher education projects	25
Criteria Four:	Proposal amount	35
Criteria Five:	Total calendar days for completion of project if applicable	10

4.1 CRITERIA

TSTC may select the Proposal that offers the “best value” for the institution based on the published selection criteria and on its ranking evaluation. TSTC may first attempt to negotiate a contract with the selected respondent. TSTC may discuss with the selected respondent options for a scope or time modification and any price change associated with the modification. If TSTC is unable to reach a contract with the selected respondent, TSTC may formally end negotiations with that respondent and proceed to the next “best value” respondent in the order of the selection ranking until a contract is reached or all Proposals are rejected. TSTC is not obligated to select the Respondent offering the most attractive economic terms if that Respondent is not the most advantageous to TSTC overall, as determined by TSTC.

Best Value Criteria

- The quality, availability, and adaptability of the supplies, materials, equipment, or contractual services to the particular use required.
- The number and scope of conditions attached to the RFP.
- The ability, capacity, and skill of the proposer to perform the contract or provide the service required.
- Whether the proposer can perform the contract or provide the service promptly, or within the time required, without delay or interference.
- The character, responsibility, integrity, reputation, and experience of the proposer.
- The quality of performance of previous contracts or services;
- Any previous or existing noncompliance by the proposer with specification requirements relating to time of submission of specified data such as photos of equipment, samples, models, drawings, certificates, or other information; the sufficiency of the financial resources and ability of the proposer to perform the contract or provide the service;
- The ability of the proposer to provide future maintenance, repair parts, and service for the use of the contract.
- The purchase price:
- Any relevant criteria specifically listed in the RFP or request for proposals.

SECTION 5: CONTRACT

Any Contract awarded as a result of this RFP will contain the general terms and conditions listed below in this Section. Subcontractors are also obliged to comply with these provisions.

SERVICE AGREEMENT

This Service Agreement, hereinafter referred to as the “Agreement”, is made and entered into by and between **Texas State Technical College**, an institution of higher education and an agency of the State of Texas (hereinafter referred to as “TSTC”), and **[Insert the proper legal name of Contractor]** a/an **[insert type of business entity—individual, corporation, partnership, non-profit organization, etc.]**, with its principal place of business at **[insert address of the contractor]** (hereinafter referred to as the “Contractor”). Contractor and TSTC may individually be referred to as a “Party” or collectively as “Parties” to this Agreement.

WHEREAS, on May 17, 2019, TSTC issued a Request for Proposal RFP-19-PG-003, for Air Conditioning Technology Building Renovation Waco Campus; and

WHEREAS, Contractor submitted a proposal dated Monday, June 10, 2019 2:00 PM CST (“Proposal”) and Contractor was selected to provide Air Conditioning Technology Building Renovation Waco Campus;

Now, therefore, the Parties agree as follows:

ARTICLE 1 BINDING DOCUMENTS

- 1.01 This Agreement shall provide for **[Insert type of service(s) RFP issued for]** (“Services”) described in and in the manner required by the following documents, attached to and incorporated as part of this Agreement for all purposes:
- (a) This Agreement
 - (b) Exhibit A: RFP and all attachments thereof
 - (c) Exhibit B: Contractor’s proposal including all negotiations and best and final offer, HUB Subcontracting Plan
 - (d) Exhibit X: Add whatever other exhibits you may have if necessary**
 - (e) **Exhibit X: Contractor’s contract [if applicable]**
- 1.02 In case any conflict between this Agreement and any of the documents specified in Section 1.01, the following shall control in this order of priority:
- (a) This Agreement
 - (b) Exhibit A: RFP and all attachments thereof
 - (c) Exhibit B: Contractor’s proposal including all negotiations and best and final offer, HUB Subcontracting Plan
 - (d) Exhibit X: Add whatever other exhibits you may have if necessary**
 - (e) **Exhibit X: Contractor’s contract [if applicable]**

- 1.03 Contractor represents and warrants that it has the requisite qualifications, experience, personnel and other resources to perform this job in the manner required by this Agreement.

ARTICLE 2 TERM OF AGREEMENT

- 2.01 Initial Term: This initial term of this Agreement shall begin **[Choose (a) or (b) and delete the other.]** (a) on the effective date as specified on the Notice of Award or (b) on the date the Agreement is signed by the TSTC delegated authority, who shall sign after the Contractor signs, and shall terminate not later than **twelve (12) months** after that date unless renewed or terminated in accordance with the terms of the Agreement.
- 2.02 Renewal Terms: TSTC has the option to renew the Agreement for **four (4) successive terms, with each Renewal Term being twelve (12) month periods**, upon written notice to the Contractor at least **thirty (30) days** prior to the expiration of the Initial Term or any Renewal Term.

ARTICLE 3 AUTHORIZED CONTRACT SUM

[Choose 3.01 OR 3.02 and 3.03 and delete the other. Amend language and re-number as necessary.]

- 3.01 TSTC shall pay Contractor as provided herein the sum of **[XXX.XX per month (per service) – amend as necessary based on agreed-upon pricing; delete brackets]** upon the receipt of invoicing as specified in Part 6.
- 3.02 Indefinite Quantity. The overall maximum value of this Agreement is indefinite, subject to the contractual authority delegated by the TSTC Board of Regents to the TSTC representative (“Representative”). The cost of each specifically authorized project will be established in an “Authorization to Commence Work” issued by the Representative. Established cost amounts shall not be increased except by written change order to a previously issued Authorization to Commence Work executed by TSTC and the Contractor.
- 3.03 No Minimum Amount of Work: It is expressly understood that TSTC is under no obligation to request any services from Contractor and no minimum amount of work is required under this Agreement. All service requests will be made by TSTC on an as-needed basis, subject to future agreement on the scope of the work and its cost.

ARTICLE 4 LOSS OF FUNDING

- 4.01 Performance of the Services specified under the Agreement may be dependent upon the appropriation and allotment of funds by the Texas State Legislature (the "Legislature") and/or allocation of funds by the Board of Regents of Texas State Technical College (the "Board"). If the Legislature fails to appropriate or allot the necessary funds, or the Board fails to allocate the necessary funds, then TSTC will issue written notice to Contractor and TSTC may terminate the Agreement without further duty or obligation hereunder. Contractor acknowledges that appropriation, allotment, and allocation of funds are beyond the control of TSTC.

ARTICLE 5 SUBCONTRACTING WITH HISTORICALLY UNDERUTILIZED BUSINESSES

[Delete this section if not applicable and renumber.]

5.01 To the extent applicable, Contractor shall subcontract the Services to historically underutilized businesses (“HUB(s)”) in accordance with Contractor’s HUB Subcontracting Plan (“HSP”) set forth in **Exhibit X** entitled “HUB Subcontracting Plan,” attached and incorporated for all purposes. In accordance with the HSP, Contractor shall submit to TSTC information necessary to assure that Contractor is adhering to the HSP, and TSTC may conduct audits to assure that Contractor’s is adhering to the HSP. No changes to the HSP may be made unless approved in writing by TSTC. Except as specifically provided in the HSP, Contractor shall not subcontract any of its duties or obligations under this Agreement, in whole or in part.

ARTICLE 6 INVOICING AND PAYMENT

6.01 Invoicing. Contractor will invoice TSTC for services performed. Each invoice will be accompanied by documentation that TSTC may reasonably request to support the invoice amount. Each invoice must reference TSTC’s valid purchase order number and be sent to one of TSTC’s billing addresses:

Texas State Technical College 3801 Campus Drive Waco, TX 76705 wacoinvoice@tstc.edu Fax: 254-867-3792	Texas State Technical College 1902 N. Loop 499 Harlingen, TX 78550 harlingeninvoice@tstc.edu Fax: 956-364-5173
---	--

6.02 Payment Terms. Notwithstanding any term or condition in the Agreement to the contrary, all invoices shall be payable to Contractor within thirty (30) days after TSTC’s receipt of invoice and delivery of the Services in accordance with the Texas Prompt Payment Act, currently codified in Section 2251, Texas Government Code. Interest shall be payable by TSTC on all past due amounts at the rate specified in Section 2251.025 of such Code. Notwithstanding anything to the contrary, Contractor understands and acknowledges that TSTC’s payment processes are stipulated by the Texas Prompt Payment Act, and nothing in the Agreement shall be construed to prevent or restrict TSTC from full compliance with such Act.

6.03 Payment Method. TSTC will pay Contractor with a credit card or direct deposit payment. TSTC will provide a direct deposit form to the Contractor upon request.

6.04 Payment of Debt or Delinquency to the State. Pursuant to Sections 2107.008 and 2252.903, Texas Government Code, Contractor agrees that any payments owing to Contractor under the Agreement may be applied directly toward any debt or delinquency that Contractor owes the State of Texas or any agency of the State of Texas regardless of when it arises, until such debt or delinquency is paid in full.

6.05 State Auditor’s Office. Contractor understands that acceptance of funds under the Agreement constitutes acceptance of the authority of the Texas State Auditor's Office, or any successor agency (collectively, “Auditor”), to conduct an audit or investigation in connection with those funds pursuant to Sections 51.9335(c), 73.115(c) and 74.008(c), Texas Education Code. Contractor agrees to cooperate with the Auditor in the conduct of the audit or investigation, including without limitation providing all records requested. Contractor will include this provision in all contracts with permitted subcontractors.

- 6.06 Tax Exemption. Contractor understands and accepts that TSTC, as an agency of the State of Texas, is exempt from most State and Federal taxes. Contractor will not attempt to pay taxes on TSTC's behalf and TSTC will not reimburse contractor for any taxes paid. A tax exempt certificate is available to contractor upon request.

ARTICLE 7 OWNERSHIP AND USE OF WORK MATERIAL, IF APPLICABLE

- 7.01 All drawings, specifications, plans, computations, sketches, data, records, photographs, tapes, renderings, models, publications, statements, accounts, reports, studies, and other materials prepared by Contractor or any Contractor's subcontractor in connection with the Services (collectively, "Work Material"), whether or not accepted or rejected by TSTC, are the property of TSTC and for its use and reuse at any time without further compensation and without any restrictions.
- 7.02 Contractor hereby grants and assigns to TSTC all rights and claims of whatever nature and whether now or hereafter arising in and to the Work Material and will cooperate fully with TSTC in any steps TSTC may take to obtain patent, copyright, trademark or like protections with respect to the Work Material.
- 7.03 TSTC will have the right to use the Work Material for the completion of the Services or otherwise. TSTC may, at all times, retain the originals of the Work Material.
- 7.04 The Work Material will not be used or published by Contractor or any other party unless expressly authorized by TSTC in writing. Contractor will treat all Work Material as confidential.

ARTICLE 8 INDEMNIFICATION

- 8.01 CONTRACTOR SHALL DEFEND, INDEMNIFY, AND HOLD HARMLESS THE STATE OF TEXAS, ITS OFFICERS AND EMPLOYEES, AND TEXAS STATE TECHNICAL COLLEGE, THE TEXAS STATE TECHNICAL COLLEGE SYSTEM, ITS OFFICERS, REGENTS, EMPLOYEES AND CONTRACTORS, FROM AND AGAINST ALL CLAIMS, ACTIONS, SUITS, DEMANDS, PROCEEDINGS, COSTS, DAMAGES, AND LIABILITIES, INCLUDING WITHOUT LIMITATION ATTORNEYS' FEES AND COURT COSTS, ARISING OUT OF, CONNECTED WITH, OR RESULTING FROM ANY ACTS OR OMISSIONS OF CONTRACTOR OR ANY AGENT, EMPLOYEE, SUBCONTRACTOR, OR SUPPLIER OF CONTRACTOR IN THE EXECUTION OR PERFORMANCE OF THIS AGREEMENT. CONTRACTOR SHALL COORDINATE ITS DEFENSE WITH THE TEXAS ATTORNEY GENERAL AS REQUESTED BY TEXAS STATE TECHNICAL COLLEGE.
- 8.02 PARAGRAPH 8.01 IS NOT INTENDED TO AND SHALL NOT BE CONSTRUED TO REQUIRE CONTRACTOR TO INDEMNIFY OR HOLD HARMLESS THE STATE OF TEXAS, TEXAS STATE TECHNICAL COLLEGE OR TEXAS STATE TECHNICAL COLLEGE SYSTEM FOR ANY CLAIMS OR LIABILITIES RESULTING FROM THE NEGLIGENT ACTS OR OMISSION OF TEXAS STATE TECHNICAL COLLEGE, TEXAS STATE TECHNICAL COLLEGE SYSTEM OR ITS EMPLOYEES.

ARTICLE 9 INSURANCE

- 9.01 Consistent with its status as an independent contractor, Contractor will obtain and maintain in force for the duration of this Agreement and any extensions thereof, at Contractor's sole expense, and to cause its agents, suppliers and permitted Subcontractors (if any) to maintain at their sole expense, the insurance coverage

obtained from companies authorized to do business in Texas or eligible surplus lines insurers operating in accordance with the Texas Insurance Code.

- 9.02 TSTC in no way warrants that these limits are sufficient to protect the Contractor from liabilities that might arise out of the performance of the Services. The Contractor will assess its own risks and, if it deems appropriate or prudent, maintain higher limits or broader coverages. The Contractor is not relieved of any liability or other obligations assumed by reason of its failure to obtain or maintain insurance in sufficient amounts, duration, or types.
- 9.03 Contractor agrees to furnish insurance certificates reflecting the following coverage: **[Talk with Chris Martin and edit as necessary for a specific RFP.]**
- i. Workers Compensation: Statutory Limits
 - ii. Employer's Liability: \$1,000,000 per accident and employee
 - iii. Commercial General Liability (including contractual liability): \$2,000,000 per occurrence
 - iv. Product/Completed Ops: \$2,000,000 aggregate
 - v. Auto Liability: \$1,000,000 combined single limit
 - vi. Professional Liability: \$1,000,000 (if applicable)
 - vii. All other insurance required by state or federal law
- 9.04. All policies (except Workers' Compensation) shall name TSTC as an Additional Insured. A Waiver of Subrogation in favor of TSTC and thirty (30) day notice of cancellation is required on all policies.
- 9.05 CERTIFICATES OF INSURANCE VERIFYING THE SPECIFIED REQUIREMENTS SHALL BE PROVIDED TO TSTC PRIOR TO COMMENCEMENT OF SERVICES IN ACCORDANCE WITH THE NOTICES SECTION PROVIDED HEREIN. CONTRACTOR WILL MAINTAIN INSURANCE AS REQUIRED HEREIN FOR THE TERM OF THE AGREEMENT AND SHALL PROVIDE RENEWAL CERTIFICATES TO TSTC AS APPLICABLE.
- 9.06 If a policy contains deductible provisions, Contractor shall be responsible for payment of the deductible amount for any claim(s) or the pursuit of any claim(s) or asserted claim(s) against TSTC, its agents, employees or representatives.
- 9.07 CONTRACTOR ACKNOWLEDGES AND UNDERSTANDS THAT TSTC DOES NOT MAINTAIN AND WILL NOT OBTAIN INSURANCE OF ANY TYPE TO PROTECT CONTRACTOR AGAINST ANY LOSS, DAMAGE OR INJURY THAT MAY IN ANY WAY RESULT FROM CONTRACTOR'S PERFORMANCE OF THE SERVICES.

ARTICLE 10 BONDS [if applicable]

- 10.01 Contractor is required to tender to TSTC, in accordance with the Notices section herein, prior to commencing the Services, performance and payment bonds ("Bonds"), as required by Chapter 2253, Texas Government Code.
- 10.02 Each bond shall be executed by a corporate surety or sureties authorized to do business in the State of Texas and acceptable to TSTC and in compliance with the relevant provisions of the Texas Insurance Code. If Bonds are for more than ten (10) percent of the surety's capital and surplus, TSTC may require certification that the

company has reinsured the excess portion with one or more reinsurers authorized to do business in the State. A reinsurer may not reinsure for more than ten (10) percent of its capital and surplus. If a surety loses its authority to do business in the State of Texas, Contractor shall, within thirty (30) days after such loss, furnish a replacement bond at no added cost to TSTC.

- 10.03 Contractor shall provide Bonds before the commencement of the Services described herein. Bonds shall be accompanied by a valid power of attorney (issued by the surety company and attached, signed and sealed with the corporate embossed seal, to the Bonds) authorizing the attorney-in-fact who signs the Bonds to commit the company to the terms of the Bonds, and stating any limit in the amount for which the attorney can issue a single bond.
- 10.04 IF FOR ANY REASON A STATUTORY PAYMENT OR PERFORMANCE BOND IS NOT HONORED BY THE SURETY, CONTRACTOR SHALL FULLY INDEMNIFY AND HOLD OWNER HARMLESS OF AND FROM ANY COSTS, LOSSES, OBLIGATIONS OR LIABILITIES IT INCURS AS A RESULT.

ARTICLE 11 CONFIDENTIALITY

- 11.01 All information owned, possessed, or used by TSTC that is communicated to, learned, developed or otherwise acquired by Contractor in the performance of services for TSTC, that is not generally known to the public, will be confidential and Contractor will not, beginning on the date of first association or communication between TSTC and Contractor and continuing throughout the term of this Agreement and any time thereafter, disclose, communicate or divulge, or permit disclosure, communication or divulgence, to another or use for Contractor's own benefit or the benefit of another, any confidential information, unless required by law.
- 11.02 FERPA Protection of Confidential Data. To the extent that 34 Code of Federal Regulations § 99.33(a)(2) is applicable, Contractor agrees to abide by the limitations on re-disclosure of personally identifiable information from education records set forth in The Family Educational Rights and Privacy Act and with the terms set forth in this subsection. 34 FR 99.33 (a)(2) states that the officers, employees and agents of a party that receives education record information from TSTC may use the information, but only for the purposes for which the disclosure was made. Definition: Covered data and information (CDI) includes paper and electronic student education record information supplied by Institution, as well as any data provided by TSTC's students to the Contractor. Acknowledgment of Access to CDI: Contractor acknowledges that the Agreement allows the Contractor access to CDI. Prohibition on Unauthorized Use or Disclosure of CDI: Contractor agrees to hold CDI in strict confidence. Contractor shall not use or disclose CDI received from or on behalf of TSTC (or its students) except as permitted or required by the Agreement, as required by law, or as otherwise authorized in writing by TSTC. Contractor agrees not to use CDI for any purpose other than the purpose for which the disclosure was made. Upon termination, cancellation, expiration or other conclusion of the Agreement, Contractor shall return all CDI to TSTC or, if return is not feasible, destroy any and all CDI. Reporting of Unauthorized Disclosures or Misuse of Covered Data and Information: Contractor shall, within one day of discovery, report to TSTC any use or disclosure of CDI not authorized by this Agreement or in writing by TSTC. Contractor's report shall identify: (i) the nature of the unauthorized use or disclosure, (ii) the CDI used or disclosed, (iii) who made the unauthorized use or received the unauthorized disclosure, (iv) what Contractor has done or shall do to mitigate any deleterious effect of the unauthorized use or disclosure, and (v) what corrective action Contractor has taken or shall take to prevent future similar unauthorized use or disclosure. Contractor shall provide such other information, including a written report, as reasonably requested by Institution.

11.03 Protected Data Security. For purposes of this section, "TSTC Confidential Information" means records maintained by TSTC, and records obtained by Contractor from TSTC under this Agreement, including (1) records and data provided electronically, on paper, or via online access or e-mail, (2) records and data that Contractor has converted into another format or medium (such as handwritten or electronic notes), and (3) records and data incorporated in any manner into Contractor's records, files or data compilations.

- (a) To the extent applicable, Contractor shall protect the confidentiality of TSTC Information and comply with all statutory, regulatory and Agreement requirements. Contractor's protection of the confidentiality of TSTC Information will survive the termination of this Agreement. Contractor shall keep and maintain complete and accurate records sufficient to allow TSTC, the Texas State Auditor's Office, the United States government, and their authorized representatives to determine Contractor's compliance with this Agreement. Contractor shall be responsible and liable for any and all damages, without limitations, resulting from a breach by Contractor including damages and losses of third parties. Contractor shall reimburse TSTC, without limitations, for any costs incurred by TSTC in reimbursing third parties damaged by Contractor's breach and costs incurred in attempts by TSTC to limit third party losses resulting from Contractor's breach. Contractor agrees to accept liability, without limitations, for any damage to TSTC's hardware, software, or TSTC Information when such damage is caused by the actions or negligence of employees, contractors, sub-contractors or agents of Contractor, whether or not the individual was an authorized User under this Agreement.
- (b) Security Breach Notification. To the extent applicable, Contractor agrees to notify TSTC as soon as it becomes aware of any actual or unintended access of the TSTC data that may access, process, or store data, files, confidential information or personal data produced under, provided under or related to this Agreement or any Scope of Work subject to this Agreement. Unintended access includes, but is not limited to, compromise by a computer worm, search engine web crawler, password compromise or access by an unauthorized individual or automated program. Contractor agrees to notify TSTC within twenty-four (24) hours of the discovery of the actual or suspected unintended access.
- (c) Disposal. To the extent applicable, Contractor shall dispose of any TSTC information and any copies thereof after the limited purposes of the Agreement or any Statements of Work are achieved, except for TSTC information possessed by any court. Disposal means the return of TSTC information to TSTC or the destruction of TSTC information, as directed by TSTC. Disposal includes deletion of personal identifiers in lieu of destruction. In any case, Contractor shall dispose of all TSTC information within thirty (30) calendar days after the termination, cancellation, or expiration of the Agreement.
- (d) Access Limited. To the extent applicable, Contractor shall limit access to TSTC information to Contractor's employees who need access to achieve the limited purposes of the Agreement or any related Statement of Work.
- (e) Mobile Device and Removal. To the extent applicable, Contractor shall not place TSTC information on mobile, remote, or portable storage devices, or remove storage media from Contractor's facility, without the prior written authorization of TSTC.

(f) Acceptance Testing. To the extent applicable, upon receipt of the initial feature set of the Contractor's services prior to launch of the Contractor's services, or any subsequent enhancements to the Contractor's services both Parties will test the Deliverable for compliance with the specifications in the detailed design document provided to TSTC by Contractor in accordance with TSTC's launch checklist (Acceptance Testing). If a dispute arises regarding testing criteria, TSTC will make the final determination. Acceptance of any Deliverable will occur upon the earlier of either: (a) Contractor's receipt of a notice from TSTC stating that the Deliverable has met the Acceptance Criteria; or (b) 60 days, or other mutually agreeable time period, after the date of delivery, unless notice of non-acceptance (including specific reasons for non-acceptance) is provided to Contractor within the 60-day period. Contractor will use commercially reasonable efforts to correct any non-conformance in a timely manner. The Parties will provide each other with commercially reasonable assistance as necessary to correct any non-conformance, including information necessary to recreate the error or non-conformity identified. The Parties will work together in good faith to complete Acceptance Testing according to any applicable development schedule. Upon successful completion of Acceptance Testing the Parties will notify each other of final acceptance.

11.04 Notwithstanding any provisions of this Agreement to the contrary, Contractor understands that TSTC will comply with the Texas Public Information Act, Chapter 552, Texas Government Code, as interpreted by judicial opinions and opinions of the Attorney General of the State of Texas. TSTC agrees to notify Contractor of a request for information related to Contractor's work under this Agreement. The Contractor will cooperate with TSTC in the production of documents responsive to the request. The Contractor may request that TSTC seek an opinion from the Attorney General of the State of Texas. However, TSTC will not honor Contractor's request for an opinion if the request is not based upon a reasonable interpretation of the Texas Public Information Act. Additionally, Contractor shall notify TSTC's Office of General Counsel of receipt of any third party requests for information that was provided by the State of Texas for use in conducting this Agreement. Contractor understands this Agreement and all data and other information generated or otherwise obtained in the performance of its responsibilities under this Agreement may be subject to the Texas Public Information Act. Contractor agrees to maintain the confidentiality of information received from the State of Texas during the performance of this Agreement, including information which discloses confidential personal information particularly, but not limited to, social security numbers.

ARTICLE 12 PUBLICITY

12.01 Except when defined as part of the Services, Contractor will not make any press releases, public statements, or advertisement referring to the Services or the engagement of Contractor as an independent Contractor of TSTC in connection with the Services, or release any information relative to the Services for publication, advertisement or any other purpose without the prior written approval of TSTC, which approval may be withdrawn by TSTC with written notice to the Contractor. All name, logos and symbols of TSTC ("TSTC Marks") are owned by the Board of Regents. No displays or other advertising may state/imply that TSTC endorses a particular Contractor's Services. Any use of TSTC marks must have prior written approval of TSTC. In specific instances Contractor can reference TSTC by name but only as a customer of Contractor and may appear on Contractor's promotional material or website so long as reference does not endorse Contractor. Contractor will obtain assurances similar to those contained in this Section from persons, contractors, and subcontractors retained by Contractor.

ARTICLE 13 NOTICES

13.01 Any and all notices, demands, or other communications required or desired to be given hereunder by any Party shall be in writing and shall be validly given or made to another Party if personally served, or if deposited in the United States mail, certified or registered, postage prepaid, return receipt requested. If such notice or demand is served personally, notice shall be deemed constructively made at the time of such personal service. If such notice, demand or other communication is given by mail, such notice shall be conclusively deemed given five days after deposit thereof in the United States mail addressed to the Party to whom such notice, demand or other communication is to be given at the addresses as listed below. Any Party hereto may change its address for purposes of this paragraph by written notice given in the manner provided above.

If to TSTC:

[Insert Name, Title, Address]

With copies to:

TSTC Procurement Division
Office of Contract Administration
3801 Campus Drive
Waco, TX 76705
ContractAdmin@tstc.edu

If to Contractor:

[Insert Name, Title, Address]

ARTICLE 14 DISPUTE RESOLUTION

[Choose (14.01) or (14.02) and delete the other, and re-number.]

14.01 [Insert if Agreement Value is estimated to be less than \$25,000] To the extent that Chapter 2260, Texas Government Code, is applicable to this Agreement and is not preempted by other applicable law, the dispute resolution process provided for in Chapter 2260 and the related rules adopted by the Texas Attorney General pursuant to Chapter 2260, shall be used by TSTC and Contractor to attempt to resolve any claim for breach of contract made by Contractor that cannot be resolved in the ordinary course of business. The Senior Executive Director of TSTC Procurement Services shall examine Contractor's claim and any counterclaim and negotiate with Contractor in an effort to resolve such claims. The Parties hereto specifically agree that (i) neither the execution of this Agreement by TSTC nor any other conduct, action or inaction of any representative of TSTC relating to this Agreement constitutes or is intended to constitute a waiver of TSTC's or the state's sovereign immunity to suit; and (ii) TSTC has not waived its right to seek redress in the courts.

14.02 [Insert if Agreement Value is estimated to be more than \$25,000] To the extent that Chapter 2260, Texas Government Code, as it may be amended from time to time ("Chapter 2260"), is applicable to this Agreement and is not preempted by other applicable law, the dispute resolution process provided for in Chapter 2260 shall be used, as further described herein, by TSTC and Contractor to attempt to resolve any claim for breach of contract made by Contractor:

- 14.03 Contractor's claims for breach of this Agreement that the Parties cannot resolve pursuant to other provisions of this Agreement or in the ordinary course of business shall be submitted to the negotiation process provided in subchapter B of Chapter 2260. To initiate the process, Contractor shall submit written notice, as required by subchapter B of Chapter 2260, to TSTC in accordance with the notice provisions in this Agreement. Contractor's notice shall specifically state that the provisions of subchapter B of Chapter 2260 are being invoked, the date and nature of the event giving rise to the claim, the specific Agreement provision that TSTC allegedly breached, the amount of damages Contractor seeks, and the method used to calculate the damages. Compliance by Contractor with subchapter B of Chapter 2260 is a required prerequisite to Contractor's filing of a contested case proceeding under subchapter C of Chapter 2260. The Senior Executive Director of TSTC Procurement Services of TSTC, or such other officer of TSTC as may be designated from time to time by TSTC, by written notice thereof to Contractor in accordance with the notice provisions in this Agreement, shall examine Contractor's claim and any counterclaim and negotiate with Contractor in an effort to resolve such claims.
- 14.04 If the Parties are unable to resolve their disputes under subparagraph (a) of this section, the contested case process provided in subchapter C of Chapter 2260 is Contractor's sole and exclusive process for seeking a remedy for any and all of Contractor's claims for breach of this Agreement by TSTC.
- 14.05 Compliance with the contested case process provided in subchapter C of Chapter 2260 is a required prerequisite to seeking consent to sue from the Legislature under Chapter 107 of the Texas Civil Practices and Remedies Code. The Parties hereto specifically agree that (i) neither the execution of this Agreement by TSTC nor any other conduct, action or inaction of any representative of TSTC relating to this Agreement constitutes or is intended to constitute a waiver of TSTC's or the state's sovereign immunity to suit and (ii) TSTC has not waived its right to seek redress in the courts.
- 14.06 The submission, processing and resolution of Contractor's claim is governed by the published rules adopted by the Texas Attorney General pursuant to Chapter 2260, as currently effective, hereafter enacted or subsequently amended.
- 14.07 TSTC and Contractor agree that any periods set forth in this Agreement for notice and cure of defaults are not waived.

ARTICLE 15 SOFTWARE PROVISIONS [if applicable]

- 15.01 Access by Individuals with Disabilities. Contractor represents and warrants ("EIR Warranty") that the electronic and information resources and all associated information, documentation, and support that it provides to TSTC under this Agreement (collectively, "EIRs") comply with the "Accessibility Standards" set forth in Title 1, Part 10, Rules 213.30 and 213.36 of the Texas Administrative Code. To the extent Contractor becomes aware that the EIRs, or any portion thereof, do not satisfy the EIR Warranty, then Contractor represents and warrants that it will, at no cost to TSTC, either (1) perform all necessary remediation to make the EIRs satisfy the EIR Warranty; or (2) replace the EIRs with new EIRs that satisfy the EIR Warranty. Should TSTC notify Contractor in writing that the EIRs, or any portion thereof, do not comply with the EIR Warranty, and such non-compliance continues for a period of sixty days after such written notice to Contractor, then TSTC may terminate this Contract and Contractor will refund to TSTC, within thirty (30) days after the termination date, a prorated amount of any fees paid by TSTC for Services not yet properly rendered.

ARTICLE 16 INDEPENDENT CONTRACTOR

- 16.01 Contractor warrants, represents, covenants, and agrees that it is duly organized, validly existing and in good standing under the laws of the state of its incorporation or organization and is duly authorized and in good standing to conduct business in the State of Texas, that it has all necessary power and has received all necessary approvals to execute and deliver the Contract, and the individual executing the Contract on behalf of Contractor has been duly authorized to act for and bind Contractor.
- 16.02 For all purposes of this Agreement and notwithstanding any provision of this Agreement to the contrary, Contractor is an independent contractor and is not a state employee, partner, joint venturer, or agent of TSTC. Contractor will not bind nor attempt to bind TSTC to any Agreement or contract. As an independent contractor, Contractor is solely responsible for all taxes, withholdings, and other statutory or contractual obligations of any sort, including but not limited to workers' compensation insurance. Contractor is responsible for its conduct of business operations, including but not limited to employee salaries, benefits, and travel expenses.

ARTICLE 17 SUBCONTRACTORS

- 17.01 Notwithstanding any other provisions contained herein, if Contractor intends to subcontract all or a portion of the Services, Contractor must identify all proposed Subcontractors ("Subcontractors") to TSTC in its submitted Proposal. Contractor will not delegate any of its duties or responsibilities under the Agreement to any Subcontractors, except as expressly provided for in the Agreement. Subcontractors providing Services under the Agreement must meet the same requirements and level of experience required of the Contractor. The utilization of any Subcontractor for provided Services under the Agreement will not relieve the Contractor of the responsibility for ensuring the requested Goods or Services are provided in accordance with the requirements herein.

ARTICLE 18 BACKGROUND CHECKS AND IDENTIFICATION

- 18.01 DPS Background Checks. Contractor is required to do a Texas Department of Public Safety background check on each and every one of its employees or assigns that are on TSTC premises. Contractor shall share any negative background check results with TSTC prior to the employee or assign coming onto TSTC premises and TSTC, in its sole discretion, shall determine if said employee or assign shall be allowed on TSTC premises. The Contractor also ensures that any of its employees or assigns that are noted on the Department of Public Safety background reporting are in compliance with federal laws and the laws of the State of Texas.
- 18.02 Sexual Offender Search. TSTC recognizes that some sexual offenders, after having served their sentence, are no longer considered to be a threat to society, and the State of Texas has approved them to work in higher education environments. Contractor will ensure that it, and all of its subcontractors and assigns that will be on TSTC property have been searched on the Texas Public Sex Offender Registry and National Sex Offender Public Website at <https://records.txdps.state.tx.us/SexOffender/> and <http://www.nsopw.gov/> ("Registries"). The Contractor will ensure that any employees or subcontractors found on the Registries or any other state or federal sexual offender registry are in compliance with federal laws and the laws of the State of Texas regarding sexual offenders. Any employees or Subcontractors that are shown on the sexual offender registries must be documented. Documentation shall include explanation and verification of any employees or Subcontractors

that appear on the sexual offender lists; and show that those on the lists have met the requirements of the State of Texas to work on the property of higher education institutions.

- 18.03 Access and Identification. All of Contractor's personnel, while on TSTC premises, must have all of the following:
- (a) A valid State of Texas ID or driver's license
 - (b) A photo ID bearing:
 - i. the name of the company for which the individual works,
 - ii. the individual's name, and
 - iii. a recent photo of the individual.

ARTICLE 19 COMPLIANCE WITH LAW

- 19.01 Contractor warrants that it will obtain, maintain in effect, and pay the cost for all licenses, permits, or certifications that may be necessary for Contractor's performance of this Agreement.
- 19.02 Contractor will be responsible for the payment of all taxes, excises, fees, payroll deductions, employee benefits (if any), fines, penalties or other payments required by federal, state, or local law or regulation in connection with Contractor's performance of this Agreement.
- 19.03 Contractor will comply with, and will be responsible for requiring its officers and employees to comply with, all applicable federal, state, and local laws and regulations, and the rules and regulations of TSTC.
- 19.04 Tax Delinquency. If Contractor is a taxable entity as defined by Chapter 171, Texas Tax Code, then Contractor certifies that it is not currently delinquent in the payment of any taxes due under such Chapter, or that Contractor is exempt from the payment of those taxes, or that Contractor is an out-of-state taxable entity that is not subject to those taxes, whichever is applicable.
- 19.05 Certain Contracts Prohibited. Pursuant to Sections 2155.004 and 2155.006, Texas Government Code, Contractor certifies that the individual or business entity named in the Contract is not ineligible to receive the award of or payments under the Contract and acknowledges that the Contract may be terminated and payment withheld if these certifications are inaccurate.
- 19.06 Texas Family Code Child Support Certification. To the extent applicable, Pursuant to Section 231.006, Texas Family Code, Contractor certifies that it is not ineligible to receive the award of or payments under the Contract and acknowledges that the Contract may be terminated and payment may be withheld if this certification is inaccurate.
- 19.07 Franchise Tax Certification. Contractor certifies that (a) it is not currently delinquent in the payment of any franchise taxes due under Chapter 171 of the Texas Tax Code, or (b) that the Contractor is exempt from the payment of such taxes, or (c) that the Contractor is an out-of-state corporation or limited liability company that is not subject to the Texas Franchise Tax, whichever is applicable.

- 19.08 Prohibition on Contracts with Companies Boycotting Israel. Pursuant to the provisions of Chapter 2270 of the Texas Government Code, Contractor verifies that it does not boycott Israel and will not boycott Israel during the term of the Agreement.
- 19.09 Products and Materials Produced in Texas. If Contractor will provide services under the Agreement, Contractor covenants and agrees that in accordance with Section 2155.4441, Texas Government Code, in performing its duties and obligations under the Agreement, Contractor will purchase products and materials produced in Texas when such products and materials are available at a price and delivery time comparable to products and materials produced outside of Texas.
- 19.10 Ethics. TSTC officers and employees may not have a direct or indirect interest, including financial and other interests, engage in a business transaction or professional activity, or incur any obligation of any nature, that is in substantial conflict with the proper discharge of the officer's or employee's duties in the public interest. A TSTC officer or employee will not: 1) accept or solicit any gift, favor, or service that might reasonably tend to influence the officer or employee in the discharge of official duties or that the officer or employee knows, or should know, is being offered with the intent to influence the officer's or employee's official conduct; 2) accept other employment or engage in a business or professional activity that the officer or employee might reasonably expect would require or induce the officer or employee to disclose confidential information acquired by reason of the official position; 3) accept other employment or compensation that could reasonably be expected to impair the officer's or employee's independence of judgment in the performance of their official duties; 4) make personal investments that could reasonably be expected to create a substantial conflict between the officer's or employee's private interest and the public interest; or 5) intentionally or knowingly solicit, accept or agree to accept any benefit for having exercised the officer's or employee's official powers or performed their official duties in favor of another. TSTC may not use appropriated money to compensate a state employee who violates a standard of conduct. In accordance with the Texas Constitution, an officer or employee of the state may not, directly or indirectly, profit by or have a pecuniary interest in the preparation, printing, duplication, or sale of a publication or other printed material issued by a department or agency of the executive branch. A person who violates this provision may be dismissed from TSTC employment.
- 19.11 Illegal Dumping. If applicable, the Contractor shall ensure that it and all of its Subcontractors prevent illegal dumping of litter, hazardous waste, matches, medical waste, solid waste, chemicals, petroleum, rubbish, sludge, or other materials in accordance with Title 5, Texas Health and Safety Code, Chapter 365.
- 19.12 Travel and Per Diem. Contractor understands that any travel or per diem required by Contractor to perform its obligations under the Agreement will be at Contractor's expense. However, TSTC has sole discretion to and may pay Contractor's travel and per diem requests, but prior to expenditure, Contractor must have approval from TSTC in writing, and if approved by TSTC all travel and per diem that Contractor requests are subject to, and shall not exceed, the reimbursement limitations applicable to Texas state employees in conducting official state business as prescribed by applicable law, rules, and regulations including, but not limited to, Chapter 660 of the Texas Government Code, the General Appropriations Act and rules adopted by the Comptroller.
- 19.13 Outside Terms. TSTC rejects and will not be bound by Contractor's "click-wrap" terms and conditions, "browse-wrap" terms and conditions, "shrink-wrap" terms and conditions, or any other terms and conditions which can be found on an internet webpage, hereinafter collectively referred to as "Internet Terms". TSTC rejects and will not be bound by any terms and conditions on invoices or acknowledgements whether or not said invoices or acknowledgements are signed by a representative of TSTC. Said Internet Terms or invoice/acknowledgement

terms and conditions will not currently, nor in the future, bind TSTC or be made applicable to the Agreement, unless assent to said Internet Terms or invoice/acknowledgement terms and conditions is shown by the signatures of duly authorized representatives from both Parties.

ARTICLE 20 TERMINATION

- 20.01 Either Party to this Agreement may terminate this Agreement, without cause, upon [30, 60, 90] days written notice to the other Party.
- 20.02 If either Party is in default of performance of any material obligation under this Agreement, the Party that is not in default may give written notice of the default to the other Party and if the Party notified fails to correct the default within thirty (30) days or other specified period fails to satisfy the Party giving notice that the default does not exist, the Party giving notice may terminate this Agreement upon expiration of the thirty (30) day or other specified period.
- 20.03 Notwithstanding the termination or expiration of this Agreement, the provisions of this Agreement regarding indemnification, confidentiality, records, right to audit, dispute resolution, invoice and fees verification, and default shall survive the termination or expiration dates of this Agreement.
- 20.04 The termination of this Agreement shall not affect any right or remedy that has accrued to either Party at the time of termination.
- 20.05 If applicable, upon termination of this Agreement, Contractor shall deliver to the appropriate representative of TSTC all Work Material related to the services performed by Contractor together with any keys, identification badges, or equipment owned by TSTC.

ARTICLE 21 OTHER TERMS AND CONDITIONS

- 21.01 Assignment. Neither Party may assign this Agreement, in whole or in part, without the prior written consent of the other Party.
- 21.02 Venue; Governing Law. As required by Chapter 135 of the Texas Education Code, McLennan County or Travis County, Texas, will be the proper place of venue for suit on or in respect of the Agreement. The Agreement and all of the rights and obligations of the Parties hereto and all of the terms and conditions hereof will be construed, interpreted and applied in accordance with and governed by and enforced under the laws of the State of Texas.
- 21.03 Counterparts. This Agreement may be executed in one or more counterparts and may be electronically transmitted. Each counterpart shall be deemed an original and all of which shall constitute one and the same document.
- 21.04. Entire Agreement. Notwithstanding the provisions in Section 1, this Agreement supersedes all prior agreements, written or oral, between Contractor and TSTC and will constitute the entire Agreement and understanding between the Parties with respect to the subject matter hereof. The Agreement and each of its

provisions will be binding upon the Parties and may not be waived, modified, amended or altered except in writing signed by TSTC and Contractor.

- 21.05 Captions. The captions of sections and subsections in this Agreement are for convenience only and will not be considered or referred to in resolving questions of interpretation or construction.
- 21.06 Force Majeure. Neither Party to this Agreement will be liable or responsible to the other for any loss or damage, or for any delays or failure to perform, due to causes beyond its reasonable control including, but not limited to, acts of God, strikes, epidemics, war, riots, flood, fire, sabotage, or any other circumstances of like character (“force majeure occurrence”).
- 21.07 Severability. If any provision of this Agreement is held by a court of law to be illegal, invalid or unenforceable, (a) that provision shall be deemed amended to achieve as nearly as possible the same economic effect as the original provision, and (b) the legality, validity and enforceability of the remaining provisions of this Agreement shall not be affected or impaired thereby.
- 21.08 Waivers. No delay or omission by either Party in exercising any right or power arising from non-compliance or failure of performance by the other Party with any of the provisions of this Agreement shall impair or constitute a waiver of any such right or power. A waiver by either Party of any covenant or condition of this Agreement shall not be construed as a waiver of any subsequent breach of that or of any other covenant or condition of the Agreement.

IN WITNESS WHEREOF, duly authorized representatives of the Parties have agreed to the terms of this Agreement and thereby execute and deliver this Agreement to the other Party.

Texas State Technical College

Contractor

By: _____

(Authorized Signature)

(Authorized Signature)

(Printed Name)

(Printed Name)

(Title)

(Title)

(Date)

(Date)

Exhibit A:

RFP

(Attach RFP including addendums and any issued Q&A behind this page)

SAMPLE

Exhibit B:

Contractor's Proposal

(Attach Contractor's proposal with any BAFOs, HUB subcontracting plan, amendments, etc. behind this page)

SAMPLE

Exhibit C, D, E, etc.

(Attach additional exhibits as detailed in the "Binding Documents" section.)

SAMPLE

SECTION 6: FORMS

FORM A: Execution of Offer

The undersigned, in submitting this Proposal and endorsement of same, represents that he/she is authorized to obligate his/her firm, that he/she is an equal opportunity employer and will not discriminate with regard to race, color, religion, sex, national origin, age or disability; that he/she will abide by all the policies and procedures of TSTC; and that he/she has read the entire RFP package, is aware of the covenants contained herein and will abide by and adhere to the written requirements in **ALL** sections of the RFP. **Failure to manually sign this RFP Response Form will be reason for the RFP to be rejected.**

SUBMITTED BY:

Firm: _____
(OFFICIAL Firm Name)

***MUST BE SIGNED IN INK TO BE
CONSIDERED RESPONSIVE***

By: _____
(Original Signature)

Name: _____
(Typed or Printed Name)

Title: _____
(Type or Printed Title) _____
(Date)

Contact Representative: _____

Address: _____

City/ST/Zip: _____

Phone #: _____ Fax #: _____

Email: _____

***NOTE: Submit copy of Proposer's
current W-9 Form***

Taxpayer Identification #: _____

Prompt Payment Discount: _____% _____ Days

IS YOUR COMPANY A HUB VENDOR? _____ WHAT CATEGORY? _____

I hereby acknowledge receipt of the following addenda which have been issued and incorporated into the RFP Document. *(Please initial in ink beside each addenda received. If none received, leave blank)*

Addendum No. 1 _____

Addendum No. 3 _____

Addendum No. 2 _____

Addendum No. 4 _____

FORM B: DEVIATION/COMPLIANCE SIGNATURE FORM

If the undersigned Firm intends to deviate from the Specifications listed in this RFP document or Contract, all such deviations must be listed on this page, with complete and detailed conditions and information included or attached. TSTC will consider any deviations in its RFP award decisions, and TSTC reserves the right to accept or reject any RFP based upon any deviations indicated below or in any attachments or inclusions.

In the absence of any deviation entry on this form, the Firm assures TSTC of his/her full compliance with the Terms and Conditions, Specifications, and all other information contained in this RFP document.

- No Deviation
- Yes Deviations

Firm's Name: _____

Authorized Company Official's Name: _____
(Typed or printed)

Title of Authorized Representative: _____
(Typed or printed)

Signature of Authorized Company Official: _____

Date Signed: _____

If yes is checked, please list below. Attach additional sheet(s) if needed.

FORM C: NON-COLLUSION STATEMENT

“The undersigned affirms that he/she is duly authorized to execute this RFP, that this company, corporation, firm, partnership or individual has not prepared this RFP in collusion with any other proposer, and that the contents of this RFP as to prices, terms or conditions of said RFP have not been communicated by the undersigned nor by any employee or agent to any other person engaged in this type of business prior to the official opening of this RFP.”

Firm’s Name: _____

Firm’s Name: _____

Authorized Company Official’s Name: _____
(Typed or printed)

Title of Authorized Representative: _____
(Typed or printed)

Signature of Authorized Company Official: _____

Date Signed: _____

Firm hereby assigns to purchaser any and all claims for overcharges associated with this RFP which arise under the antitrust laws of the United States, 15 USCA Section 1 and which arise under the antitrust laws of the State of Texas, Business and Commerce Code, Section 15.01.

FORM D: REFERENCES

1. Company Name: _____

Address: _____

Business Phone: _____

Fax: _____

Contact Person: _____

Email: _____

Description of project or work completed: _____

2. Company Name: _____

Address: _____

Business Phone: _____

Fax: _____

Contact Person: _____

Email: _____

Description of project or work completed: _____

3. Company Name: _____

Address: _____

Business Phone: _____

Fax: _____

Contact Person: _____

Email: _____

Description of project or work completed: _____

REFERENCES

4. Company Name: _____

Address: _____

Business Phone: _____

Fax: _____

Contact Person: _____

Email: _____

Description of project or work completed: _____

5. Company Name: _____

Address: _____

Business Phone: _____

Fax: _____

Contact Person: _____

Email: _____

Description of project or work completed: _____

FORM E: Inter-Local Agreement Clause



INTERLOCAL AGREEMENT CLAUSE

Several governmental entities around the Texas State Technical College have indicated an interest in being included in this contract. Should these governmental entities decide to participate in this contract, would you, (the vendor) agree that all terms, conditions, specifications, and pricing would apply?

Yes _____

No _____

If you (the Vendor) checked yes, the following will apply:

Governmental entities utilizing interlocal agreements with the Texas State Technical College will be eligible, but not obligated, to purchase materials/services under the contract(s) awarded as a result of this solicitation. All purchases by governmental entity other than Texas State Technical College will be billed directly to that governmental entity and paid by that governmental entity. Texas State Technical College will not be responsible for another governmental entity's debts. Each governmental entity will order its own material/service as needed.

For information regarding the Educational Purchasing Cooperative of North Texas, please visit their website at the following address: <http://www.epcnt.com/INDEX.htm>.

Company Name: _____
(Typed or printed)

Title of Authorized Representative: _____
(Typed or printed)

Signature of Authorized Company Official: ____ Date Signed:

HUB Subcontracting Plan (HSP) QUICK CHECKLIST

While this HSP Quick Checklist is being provided to merely assist you in readily identifying the sections of the HSP form that you will need to complete, it is very important that you adhere to the instructions in the HSP form and instructions provided by the contracting agency.

If you will be awarding all of the subcontracting work you have to offer under the contract to only Texas certified HUB vendors, complete:

Section 1 - Respondent and Requisition Information

Section 2 a. - Yes, I will be subcontracting portions of the contract.

Section 2 b. - List all the portions of work you will subcontract, and indicate the percentage of the contract you expect to award to Texas certified HUB vendors. Section 2 c. - Yes

Section 4 - Affirmation

GFE Method A (Attachment A) - Complete an Attachment A for each of the subcontracting opportunities you listed in Section 2 b.

If you will be subcontracting any portion of the contract to Texas certified HUB vendors and Non-HUB vendors, and the aggregate percentage of all the subcontracting work you will be awarding to the Texas certified HUB vendors with which you do not have a continuous contract* in place for more than five (5) years meets or exceeds the HUB Goal the contracting agency identified in the "Agency Special Instructions/Additional Requirements", complete:

Section 1 - Respondent and Requisition Information

Section 2 a. - Yes, I will be subcontracting portions of the contract.

Section 2 b. - List all the portions of work you will subcontract, and indicate the percentage of the contract you expect to award to Texas certified HUB vendors and Non-HUB vendors.

Section 2 c. - No Section

2 d. - Yes Section 4 -

Affirmation

GFE Method A (Attachment A) - Complete an Attachment A for each of the subcontracting opportunities you listed in Section 2 b.

If you will be subcontracting any portion of the contract to Texas certified HUB vendors and Non-HUB vendors or only to Non-HUB vendors, and the aggregate percentage of all the subcontracting work you will be awarding to the Texas certified HUB vendors with which you do not have a continuous contract* in place for more than five (5) years does not meet or exceed the HUB Goal the contracting agency identified in the "Agency Special Instructions/Additional Requirements", complete:

Section 1 - Respondent and Requisition Information

Section 2 a. - Yes, I will be subcontracting portions of the contract.

Section 2 b. - List all the portions of work you will subcontract, and indicate the percentage of the contract you expect to award to Texas certified HUB vendors

and Non-HUB vendors.

Section 2 c. - No Section

2 d. - No Section 4 -

Affirmation

GFE Method B (Attachment B) - Complete an Attachment B for each of the subcontracting opportunities you listed in Section 2 b.

If you will not be subcontracting any portion of the contract and will be fulfilling the entire contract with your own resources (i.e., employees, supplies, materials and/or equipment), complete:

Section 1 - Respondent and Requisition Information

Section 2 a. - No, I will not be subcontracting any portion of the contract, and I will be fulfilling the entire contract with my own resources. Section 3 - Self Performing Justification

Section 4 - Affirmation

***Continuous Contract:** Any existing written agreement (including any renewals that are exercised) between a prime contractor and a HUB vendor, where the HUB vendor provides the prime contractor with goods or service, to include under the same contract for a specified period of time. The frequency the HUB vendor is utilized or paid during the term of the contract is not relevant to whether the contract is considered continuous. Two or more contracts that run concurrently or overlap one another for different periods of time are considered by CPA to be individual contracts rather than renewals of a vendor are entering (have entered) into "new" contracts.

HUB Subcontracting Plan (HSP)

In accordance with Texas Gov't Code §2161.252, the contracting agency has determined that subcontracting opportunities are probable under this contract. Therefore, all respondents, including State of Texas certified Historically Underutilized Businesses (HUBs) must complete and submit this State of Texas HUB Subcontracting Plan (HSP) with their response to the bid requisition (solicitation).

NOTE: Responses that do not include a completed HSP shall be rejected pursuant to Texas Gov't Code §2161.252(b).

The HUB Program promotes equal business opportunities for economically disadvantaged persons to contract with the State of Texas in accordance with the goals specified in the 2009 State of Texas Disparity Study. The statewide HUB goals defined in 34 Texas Administrative Code (TAC) §20.284 are:

- **11.2 percent for heavy construction other than building contracts,**
- **21.1 percent for all building construction, including general contractors and operative builders' contracts,**
- **32.9 percent for all special trade construction contracts,**
- **23.7 percent for professional services contracts,**
- **26.0 percent for all other services contracts, and**
- **21.1 percent for commodities contracts.**

- - Agency Special Instructions/Additional Requirements - -

SECTION 1: RESPONDENT AND REQUISITION INFORMATION

a. Respondent (Company) Name: State of Texas VID #: Point of Contact: Phone #:

E-mail Address:

b. Is your company a State of Texas certified HUB?

c. Requisition #:

- Yes - No

Fax #:

Bid Open Date:

(mm/dd/yyyy)

Rev. 2/17

Enter your company's name here: Requisition #:

SECTION 2: RESPONDENT'S SUBCONTRACTING INTENTIONS

After dividing the contract work into reasonable lots or portions to the extent consistent with prudent industry practices, and taking into consideration the scope of work to be performed under the proposed contract, including all potential subcontracting opportunities, the respondent must determine what portions of work, **including contracted staffing, goods and services will be subcontracted**. Note: In accordance with 34 TAC §20.282, a "Subcontractor" means a person who contracts with a prime contractor to work, to supply commodities, or to contribute toward completing work for a governmental entity.

6. Check the appropriate box (Yes or No) that identifies your subcontracting intentions:

- **Yes**, I will be subcontracting portions of the contract. (If **Yes**, complete Item b of this SECTION and continue to Item c of this SECTION.)
- **No**, I will not be subcontracting any portion of the contract, and I will be fulfilling the entire contract with my own resources, including employees, goods and services. (If **No**, continue to SECTION 3 and SECTION 4.)

7. List all the portions of work (subcontracting opportunities) you will subcontract. Also, based on the total value of the contract, identify the percentages of the contract you expect to award to Texas certified HUBs, and the percentage of the contract you expect to award to vendors that are not a Texas certified HUB (i.e., Non-HUB).

Item #	Subcontracting Opportunity Description	HUBs		Non-HUBs
		Percentage of the contract expected to be subcontracted to HUBs with which you do not have a continuous contract* in place for more than five (5) years .	Percentage of the contract expected to be subcontracted to HUBs with which you have a continuous contract* in place for more than five (5) years .	Percentage of the contract expected to be subcontracted to non-HUBs.
1		%	%	%
2		%	%	%
3		%	%	%
4		%	%	%
5		%	%	%
6		%	%	%
7		%	%	%
8		%	%	%
9		%	%	%
10		%	%	%
11		%	%	%
12		%	%	%
13		%	%	%
14		%	%	%
15		%	%	%
Aggregate percentages of the contract expected to be subcontracted:		%	%	%

(Note: If you have more than fifteen subcontracting opportunities, a continuation sheet is available online at <https://www.comptroller.texas.gov/purchasing/vendor/hub/forms.php>.)

c. Check the appropriate box (Yes or No) that indicates whether you will be using **only** Texas certified HUBs to perform **all** of the subcontracting opportunities you listed in SECTION 2, Item b.

- **Yes** (If **Yes**, continue to SECTION 4 and complete an "HSP Good Faith Effort - Method A (Attachment A)" for **each** of the subcontracting opportunities you listed.)
- **No** (If **No**, continue to Item d, of this SECTION.)

d. Check the appropriate box (Yes or No) that indicates whether the aggregate expected percentage of the contract you will subcontract **with Texas certified HUBs** with which you **do not** have a **continuous contract*** in place with for **more than five (5) years**, **meets or exceeds** the HUB goal the contracting agency identified on page 1 in the "Agency Special Instructions/Additional Requirements."

- **Yes** (If **Yes**, continue to SECTION 4 and complete an "HSP Good Faith Effort - Method A (Attachment A)" for **each** of the subcontracting opportunities you listed.)
- **No** (If **No**, continue to SECTION 4 and complete an "HSP Good Faith Effort - Method B (Attachment B)" for **each** of the subcontracting opportunities you listed.)

Enter your company's name here: Requisition #:

SECTION 2: RESPONDENT'S SUBCONTRACTING INTENTIONS (CONTINUATION SHEET)

This page can be used as a continuation sheet to the HSP Form's page 2, Section 2, Item b. Continue listing the portions of work (subcontracting opportunities) you will subcontract. Also, based on the total value of the contract, identify the percentages of the contract you expect to award to Texas certified HUBs, and the percentage of the contract you expect to award to vendors that are not a Texas certified HUB (i.e., Non-HUB).

Item #	Subcontracting Opportunity Description	HUBs		Non-HUBs
		Percentage of the contract expected to be subcontracted to HUBs with which you <u>do not</u> have a <u>continuous contract*</u> in place for <u>more than five (5) years.</u>	Percentage of the contract expected to be subcontracted to HUBs with which you have a <u>continuous contract*</u> in place for <u>more than five (5) years.</u>	Percentage of the contract expected to be subcontracted to non-HUBs.
16		%	%	%
17		%	%	%
18		%	%	%
19		%	%	%
20		%	%	%
21		%	%	%
22		%	%	%
23		%	%	%
24		%	%	%
25		%	%	%
26		%	%	%
27		%	%	%
28		%	%	%
29		%	%	%
30		%	%	%
31		%	%	%
32		%	%	%
33		%	%	%
34		%	%	%
35		%	%	%
36		%	%	%
37		%	%	%
38		%	%	%
39		%	%	%
40		%	%	%
41		%	%	%
42		%	%	%
43		%	%	%
Aggregate percentages of the contract expected to be subcontracted:		%	%	%

Enter your company's name here: Requisition #:

SECTION 3: SELF PERFORMING JUSTIFICATION (If you responded "No" to SECTION 2, Item a, you must complete this SECTION and continue to SECTION 4.) If you responded "No" to SECTION 2, Item a, in the space provided below explain how your company will perform the entire contract with its own employees, supplies, materials and/or equipment.

SECTION 4: AFFIRMATION

As evidenced by my signature below, I affirm that I am an authorized representative of the respondent listed in SECTION 1, and that the information and supporting documentation submitted with the HSP is true and correct. Respondent understands and agrees that, if awarded any portion of the requisition:

- The respondent will provide notice as soon as practical to all the subcontractors (HUBs and Non-HUBs) of their selection as a subcontractor for the awarded contract. The notice must specify at a minimum the contracting agency's name and its point of contact for the contract, the contract award number, the subcontracting opportunity they (the subcontractor) will perform, the approximate dollar value of the subcontracting opportunity and the expected percentage of the total contract that the subcontracting opportunity represents. A copy of the notice required by this section must also be provided to the contracting agency's point of contact for the contract no later than ten (10) working days after the contract is awarded.
- The respondent must submit monthly compliance reports (Prime Contractor Progress Assessment Report – PAR) to the contracting agency, verifying its compliance with the HSP, including the use of and expenditures made to its subcontractors (HUBs and Non-HUBs). (The PAR is available at <https://www.comptroller.texas.gov/purchasing/docs/hub-forms/ProgressAssessmentReportForm.xls>).
- The respondent must seek approval from the contracting agency prior to making any modifications to its HSP, including the hiring of additional or different subcontractors and the termination of a subcontractor the respondent identified in its HSP. If the HSP is modified without the contracting agency's prior approval, respondent may be subject to any and all enforcement remedies available under the contract or otherwise available by law, up to and including debarment from all state contracting.
- The respondent must, upon request, allow the contracting agency to perform on-site reviews of the company's headquarters and/or work-site where services are being performed and must provide documentation regarding staffing and other resources.

Signature

Reminder:

Printed Name Title Date

(mm/dd/yyyy)

If you responded "Yes" to SECTION 2, Items c or d, you must complete an "HSP Good Faith Effort - Method A (Attachment A)" for each of the subcontracting opportunities you listed in SECTION 2, Item b.

If you responded "No" SECTION 2, Items c and d, you must complete an "HSP Good Faith Effort - Method B (Attachment B)" for each of the subcontracting opportunities you listed in SECTION 2, Item b.

HSP Good Faith Effort - Method A (Attachment A)

Rev. 2/17

Enter your company's name here: Requisition #:

IMPORTANT: If you responded “Yes” to **SECTION 2, Items c or d** of the completed HSP form, you must submit a completed “HSP Good Faith Effort - Method A (Attachment A)” for **each** of the subcontracting opportunities you listed in **SECTION 2, Item b** of the completed HSP form. You may photo-copy this page or download the form at <https://www.comptroller.texas.gov/purchasing/docs/hub-forms/hub-sbcont-plan-gfe-achm-a.pdf>

SECTION A-1: SUBCONTRACTING OPPORTUNITY

Enter the item number and description of the subcontracting opportunity you listed in SECTION 2, Item b, of the completed HSP form for which you are completing the attachment.

Item Number: **Description:**

SECTION A-2: SUBCONTRACTOR SELECTION

List the subcontractor(s) you selected to perform the subcontracting opportunity you listed above in SECTION A-1. Also identify whether they are a Texas certified HUB and their Texas Vendor Identification (VID) Number or federal Employer Identification Number (EIN), the approximate dollar value of the work to be subcontracted, and the expected percentage of work to be subcontracted. When searching for Texas certified HUBs and verifying their HUB status, ensure that you use the State of Texas' Centralized Master Bidders List (CMBL) - Historically Underutilized Business (HUB) Directory Search located at <http://mycpa.cpa.state.tx.us/tpasscmbsearch/index.jsp>. HUB status code “A” signifies that the company is a Texas certified HUB.

Company Name	Texas certified HUB	Texas VID or federal EIN <small>Do not enter Social Security Numbers. If you do not know their VID / EIN, leave their VID / EIN field blank.</small>	Approximate Dollar Amount	Expected Percentage of Contract
	- Yes - No		\$	%
	- Yes - No		\$	%
	- Yes - No		\$	%
	- Yes - No		\$	%
	- Yes - No		\$	%
	- Yes - No		\$	%
	- Yes - No		\$	%
	- Yes - No		\$	%
	- Yes - No		\$	%
	- Yes - No		\$	%
	- Yes - No		\$	%
	- Yes - No		\$	%
	- Yes - No		\$	%
	- Yes - No		\$	%
	- Yes - No		\$	%
	- Yes - No		\$	%
	- Yes - No		\$	%
	- Yes - No		\$	%
	- Yes - No		\$	%
	- Yes - No		\$	%

REMINDER: As specified in SECTION 4 of the completed HSP form, if you (respondent) are awarded any portion of the requisition, you are required to provide notice as soon as practical to **all** the subcontractors (HUBs and Non-HUBs) of their selection as a subcontractor. The notice must specify at a minimum the contracting agency's name and its point of contact for the contract, the contract award number, the subcontracting opportunity they (the subcontractor) will perform, the approximate dollar value of the subcontracting opportunity and the expected percentage of the total contract that the subcontracting opportunity represents. A copy of the notice required by this section must also be provided to the contracting agency's point of contact for the contract **no later than ten (10) working days** after the contract is awarded.

HSP Good Faith Effort - Method B (Attachment B)

Rev. 2/17

Enter your company's name here: Requisition #:

IMPORTANT: If you responded “No” to **SECTION 2, Items c and d** of the completed HSP form, you must submit a completed “HSP Good Faith Effort - Method B (Attachment B)” for **each** of the subcontracting opportunities you listed in **SECTION 2, Item b** of the completed HSP form. You may photo-copy this page or download the form at <https://www.comptroller.texas.gov/purchasing/docs/hub-forms/hub-sbcont-plan-gfe-achm-b.pdf>.

SECTION B-1: SUBCONTRACTING OPPORTUNITY

Enter the item number and description of the subcontracting opportunity you listed in SECTION 2, Item b, of the completed HSP form for which you are completing the attachment.

Item Number: Description:

SECTION B-2: MENTOR PROTÉGÉ PROGRAM

If respondent is participating as a Mentor in a State of Texas Mentor Protégé Program, submitting its Protégé (Protégé must be a State of Texas certified HUB) as a subcontractor to perform the subcontracting opportunity listed in **SECTION B-1**, constitutes a good faith effort to subcontract with a Texas certified HUB towards that specific portion of work.

Check the appropriate box (Yes or No) that indicates whether you will be subcontracting the portion of work you listed in SECTION B-1 to your Protégé.

- Yes (If **Yes**, continue to SECTION B-4.)
- No / Not Applicable (If **No** or **Not Applicable**, continue to SECTION B-3 and SECTION B-4.)

SECTION B-3: NOTIFICATION OF SUBCONTRACTING OPPORTUNITY

When completing this section you **MUST** comply with items **a, b, c and d**, thereby demonstrating your Good Faith Effort of having notified Texas certified HUBs and trade organizations or development centers about the subcontracting opportunity you listed in SECTION B-1. Your notice should include the scope of work, information regarding the location to review plans and specifications, bonding and insurance requirements, required qualifications, and identify a contact person. When sending notice of your subcontracting opportunity, you are encouraged to use the attached HUB Subcontracting Opportunity Notice form, which is also available online at <https://www.comptroller.texas.gov/purchasing/docs/hub-forms/HUBSubcontractingOpportunityNotificationForm.pdf>.

Retain supporting documentation (i.e., certified letter, fax, e-mail) demonstrating evidence of your good faith effort to notify the Texas certified HUBs and trade organizations or development centers. Also, be mindful that a working day is considered a normal business day of a state agency, not including weekends, federal or state holidays, or days the agency is declared closed by its executive officer. The initial day the subcontracting opportunity notice is sent/provided to the HUBs and to the trade organizations or development centers is considered to be “day zero” and does not count as one of the seven (7) working days.

- a.** Provide written notification of the subcontracting opportunity you listed in SECTION B-1, to three (3) or more Texas certified HUBs. Unless the contracting agency specified a different time period, you must allow the HUBs at least seven (7) working days to respond to the notice prior to you submitting your bid response to the contracting agency. When searching for Texas certified HUBs and verifying their HUB status, ensure that you use the State of Texas' Centralized Master Bidders List (CMBL) - Historically Underutilized Business (HUB) Directory Search located at <http://mycpa.cpa.state.tx.us/tpasscmbsearch/index.jsp>. HUB status code “**A**” signifies that the company is a Texas certified HUB.
- b.** List the three (3) Texas certified HUBs you notified regarding the subcontracting opportunity you listed in SECTION B-1. Include the company's Texas Vendor Identification (VID) Number, the date you sent notice to that company, and indicate whether it was responsive or non-responsive to your subcontracting opportunity notice.

Company Name	Texas VID <small>(Do not enter Social Security Numbers.)</small>	Date Notice Sent <small>(mm/dd/yyyy)</small>	Did the HUB Respond?
			- Yes - No
			- Yes - No
			- Yes - No

- c.** Provide written notification of the subcontracting opportunity you listed in SECTION B-1 to two (2) or more trade organizations or development centers in Texas to assist in identifying potential HUBs by disseminating the subcontracting opportunity to their members/participants. Unless the contracting agency specified a different time period, you must provide your subcontracting opportunity notice to trade organizations or development centers at least seven (7) working days prior to submitting your bid response to the contracting agency. A list of trade organizations and development centers that have expressed an interest in receiving notices of subcontracting opportunities is available on the Statewide HUB Program's webpage at <https://www.comptroller.texas.gov/purchasing/vendor/hub/resources.php>.

d. List **two (2) trade organizations or development centers** you notified regarding the subcontracting opportunity you listed in SECTION B-1. Include the date when you sent notice to it and indicate if it accepted or rejected your notice.

Trade Organizations or Development Centers	Date Notice Sent (mm/dd/yyyy)	Was the Notice Accepted?
		- Yes - No
		- Yes - No

Page 1 of 2
(Attachment
B)

HSP Good Faith Effort - Method B (Attachment B) Cont.

Rev. 2/17

Enter your company's name here: Requisition #:
--

SECTION B-4: SUBCONTRACTOR SELECTION

Enter the item number and description of the subcontracting opportunity you listed in **SECTION 2, Item b**, of the completed HSP form for which you are completing the attachment.

a. Enter the item number and description of the subcontracting opportunity for which you are completing this Attachment B continuation page.

Item Number: Description:

b. List the subcontractor(s) you selected to perform the subcontracting opportunity you listed in **SECTION B-1**. Also identify whether they are a Texas certified HUB and their Texas Vendor Identification (VID) Number or federal Employer Identification Number (EIN), the approximate dollar value of the work to be subcontracted, and the expected percentage of work to be subcontracted. When searching for Texas certified HUBs and verifying their HUB status, ensure that you use the State of Texas' Centralized Master Bidders List (CMBL) - Historically Underutilized Business (HUB) Directory Search located at <http://mycpa.cpa.state.tx.us/tpasscmbsearch/index.jsp>. HUB status code "A" signifies that the company is a Texas certified HUB.

Company Name	Texas certified HUB	Texas VID or federal EIN <small>Do not enter Social Security Numbers. If you do not know their VID / EIN, leave their VID / EIN field blank.</small>	Approximate Dollar Amount	Expected Percentage of Contract
	- Yes - No		\$	%
	- Yes - No		\$	%
	- Yes - No		\$	%
	- Yes - No		\$	%
	- Yes - No		\$	%
	- Yes - No		\$	%
	- Yes - No		\$	%
	- Yes - No		\$	%
	- Yes - No		\$	%
	- Yes - No		\$	%

c. If any of the subcontractors you have selected to perform the subcontracting opportunity you listed in **SECTION B-1** is **not** a Texas certified HUB, provide written justification for your selection process (attach additional page if necessary):

REMINDER: As specified in SECTION 4 of the completed HSP form, if you (respondent) are awarded any portion of the requisition, you are required to provide notice as soon as practical to **all** the subcontractors (HUBs and Non-HUBs) of their selection as a subcontractor. The notice must specify at a minimum the contracting agency's name and its point of contact for the contract, the contract award number, the subcontracting opportunity it (the subcontractor) will perform, the approximate dollar value of the subcontracting opportunity and the expected percentage of the total contract that the subcontracting opportunity represents. A copy of the notice required by this section must also be provided to the contracting agency's point of contact for the contract no later than ten (10) working days after the contract is awarded.

HUB Subcontracting Opportunity Notification Form

In accordance with Texas Gov't Code, Chapter 2161, each state agency that considers entering into a contract with an expected value of \$100,000 or more shall, before the agency solicits bids, proposals, offers, or other applicable expressions of interest, determine whether subcontracting opportunities are probable under the contract. The state agency I have identified below in **Section B** has determined that subcontracting opportunities are probable under the requisition to which my company will be responding.

34 Texas Administrative Code, §20.285 requires all respondents (prime contractors) bidding on the contract to provide notice of each of their subcontracting opportunities to at least three (3) Texas certified HUBs (who work within the respective industry applicable to the subcontracting opportunity), and allow the HUBs at least seven (7) working days to respond to the notice prior to the respondent submitting its bid response to the contracting agency. In addition, at least seven (7) working days prior to submitting its bid response to the contracting agency, the respondent must provide notice of each of its subcontracting opportunities to two (2) or more trade organizations or development centers (in Texas) that serves members of groups (i.e., Asian Pacific American, Black American, Hispanic American, Native American, Woman, Service Disabled Veteran) identified in Texas Administrative Code §20.282(19)(C).

We respectfully request that vendors interested in bidding on the subcontracting opportunity scope of work identified in **Section C, Item 2**, reply no later than the date and time identified in **Section C, Item 1**. Submit your response to the point-of-contact referenced in **Section A**.

Rev. 2/

SECTION A: PRIME CONTRACTOR'S INFORMATION

Company Name: VID #:

Phone #:

(dd/yyyy)

Point-of-Contact: E-mail Address:

SECTION B: CONTRACTING STATE AGENCY AND REQUISITION INFORMATION

Agency Name:

Point-of-Contact: Phone #:

Requisition #: Bid Open Date:

(mm/dd/yyyy)

SUBCONTRACTING OPPORTUNITY RESPONSE DUE DATE, DESCRIPTION, REQUIREMENTS AND RELATED INFORMATION**1. Potential Subcontractor's Bid Response Due Date:**

If you would like for our company to consider your company's bid for the subcontracting opportunity identified below in Item 2,

SECTION

we must receive your bid response no later than

n2. Subcontracting Opportunity Scope of Work:

3. Required Qualifications: - Not Applicable

4. Bonding/Insurance Requirements: - Not Applicable

5. Location to review plans/specifications: - Not Applicable

Fax #:

FORM G – No Bid Response (Optional)

**Air Conditioning Technology Building Renovation Waco Campus
RFP No.: RFP-19-PG-003**

If your firm is unable to submit a proposal at this time, complete this form and return it to:

**Texas State Technical College
Building SSC
Procurement Office
1901 N. Loop 499
Harlingen, Texas 78550
Pedro.guardiola@tstc.edu**

by the date/time for submission of this solicitation.

I/WE DID NOT SUBMIT A PROPOSAL FOR THE FOLLOWING REASONS:
(Please place an X by all the reasons that apply)

1. ___ Do not supply the requested product/service.
2. ___ Quantities offered or scope of job is TOO SMALL to be supplied by my company.
3. ___ Qualities offered or scope of job is TOO LARGE to be supplied by my company.
4. ___ Specifications are “too constrictive” or appear to be written around a proprietary product.
5. ___ Time frame for responding was too short. (Please elaborate on your primary reason for this judgment.)
6. ___ Other reasons: _____

BY: _____
Vendor Signature Date

Printed Name & Title Phone No.

Company Name Fax No.

Form H: Proposal Form

TSTC Waco PBE Renovations for ACT

Date: _____ 2019

TEXAS STATE TECHNICAL COLLEGE WACO
3801 CAMPUS DRIVE
WACO, TEXAS 76705

Dear Madam:

The undersigned, having carefully examined the specifications, drawings, and related documents entitled:

TSTC Waco PBE Renovations for ACT

3801 Campus Drive, Waco Texas

all as prepared by Texas State Technical College Physical plant as well as all other conditions affecting the cost and/or execution of the work, proposes to furnish all materials, labor, and equipment necessary to complete the work in accordance with said documents, of which this proposal is a part, for the following sum:

TOTAL PROPOSAL: _____ Dollars (\$ _____)

(Note: All amounts shall be shown in both written and figure form. In case of discrepancy between the written amount and the figure, the written amount will govern. For alternates, check whether it is an add, deduct or no change.)

We have included, in the Proposal sum, all applicable taxes and all material and contingency allowances described in Section 01200 – PRICE AND PAYMENT.

If awarded the contract, the undersigned agrees to commence work under this contract (See Notice to Proceed) and to substantially complete the project within _____ (Proposer to fill in days) calendar days from said commencement date, unless modified by change order.

Proposer agrees to pay the **Owner \$300.00** per day, as liquidated damages, for each day the substantial completion of this project extends beyond the stipulated substantial completion date.

If notified of the acceptance of this proposal within thirty (30) days of the time set for the opening of proposals, proposer agrees within ten (10) days of notification, to execute a contract in the form of the Standard Form of Agreement Between Owner and Contractor where the Basis of Payment Is a Stipulated Sum, as amended for the above work, for the above stated compensation.

All articles as stated in Advertisement For Proposals and Instructions to Proposers, is attached to this Proposal. In accordance with instructions to Proposers, the following documents included in this Proposal Form Supplement is attached to and made a condition of the proposal:

Respectfully Submitted,

By: _____

Title: _____

Business Address with Zip Code

Telephone Number with Area Code _____

FAX Number with Area Code _____

Fill in the applicable information:

A Corporation, chartered in the State of _____

Authorized to do business in the State of Texas.

A Partnership, composed of _____, and

_____ and _____,

An Individual operating under the name of _____

_____.

END PROPOSAL FORM

TSTC Waco PBE Renovations for ACT

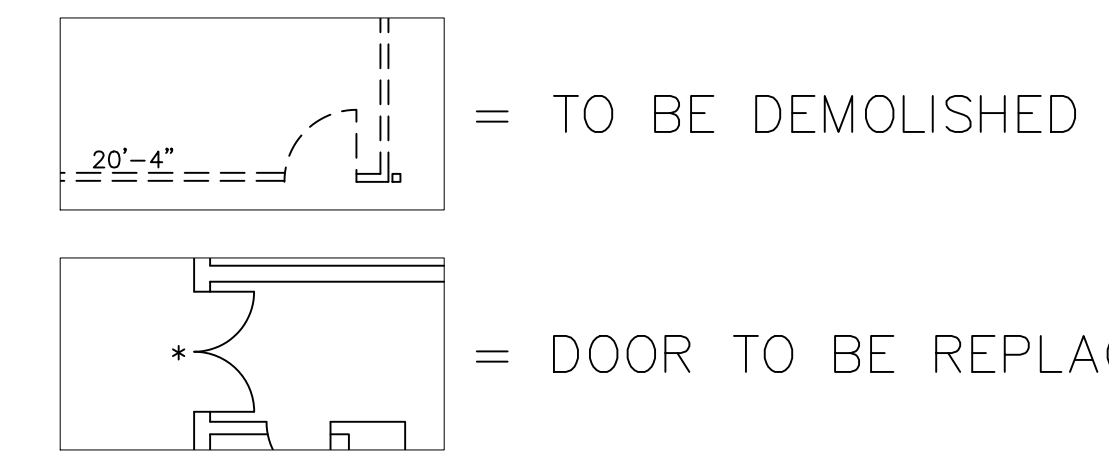
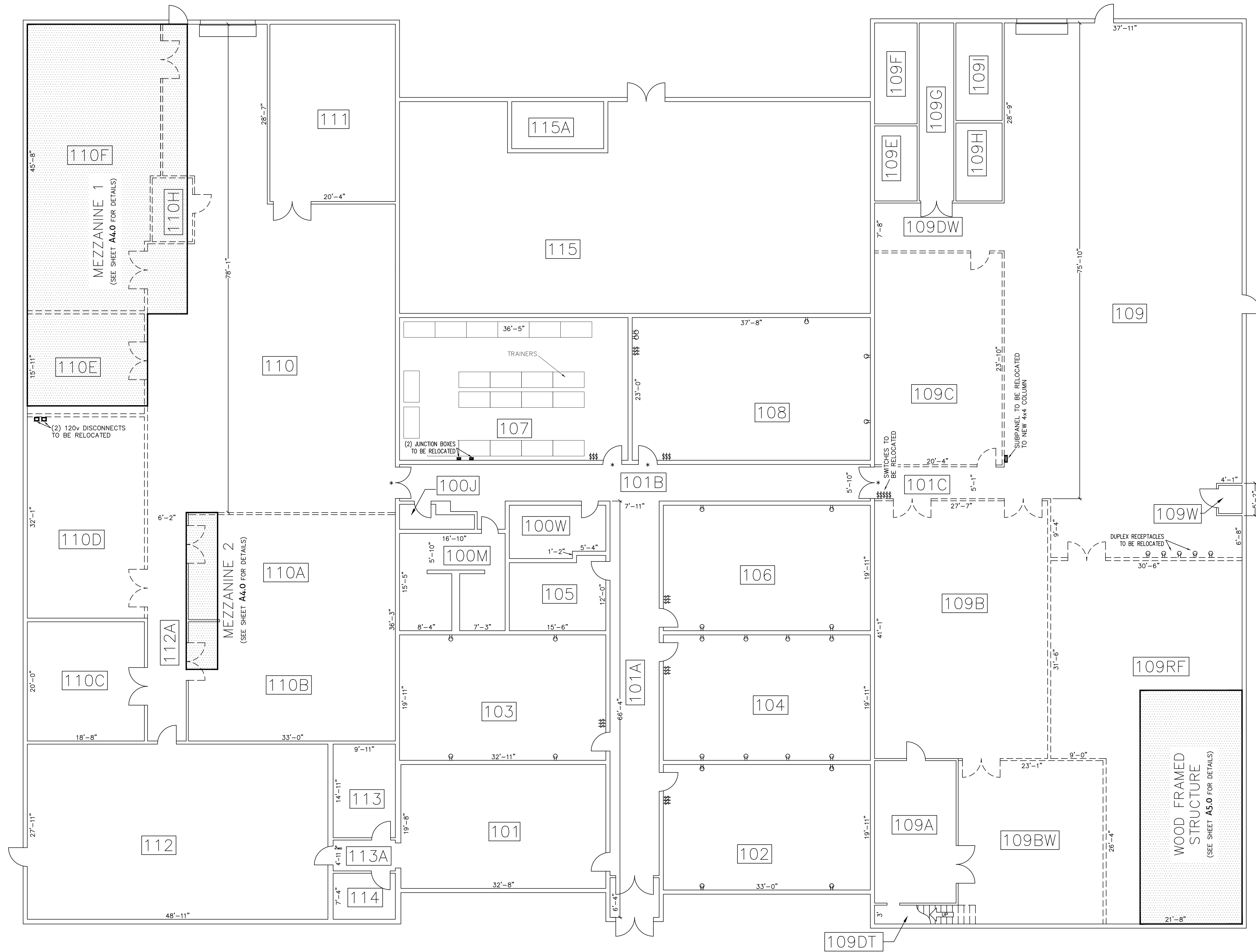

NO.	DATE	DESCRIPTION	BY



COPYRIGHT 2019 Texas State Technical College (TSTC)
 All rights reserved. No part of this publication may be reproduced by photocopying, recording, or by any other means, nor reused or modified by any means for reuse on any project other than originally intended without the prior written permission of TSTC.

Proposed ACT Renovations for
TSTC WACO
 3801 Campus Dr. Waco, TX 76705

Existing Floor Plan
 SCALE: 1/8" = 1'-0"
 JOB NO:
 DRAWN BY: M. Schumacher
 DATE: 04/23/2019

SHEET
A1.0
 OF 5

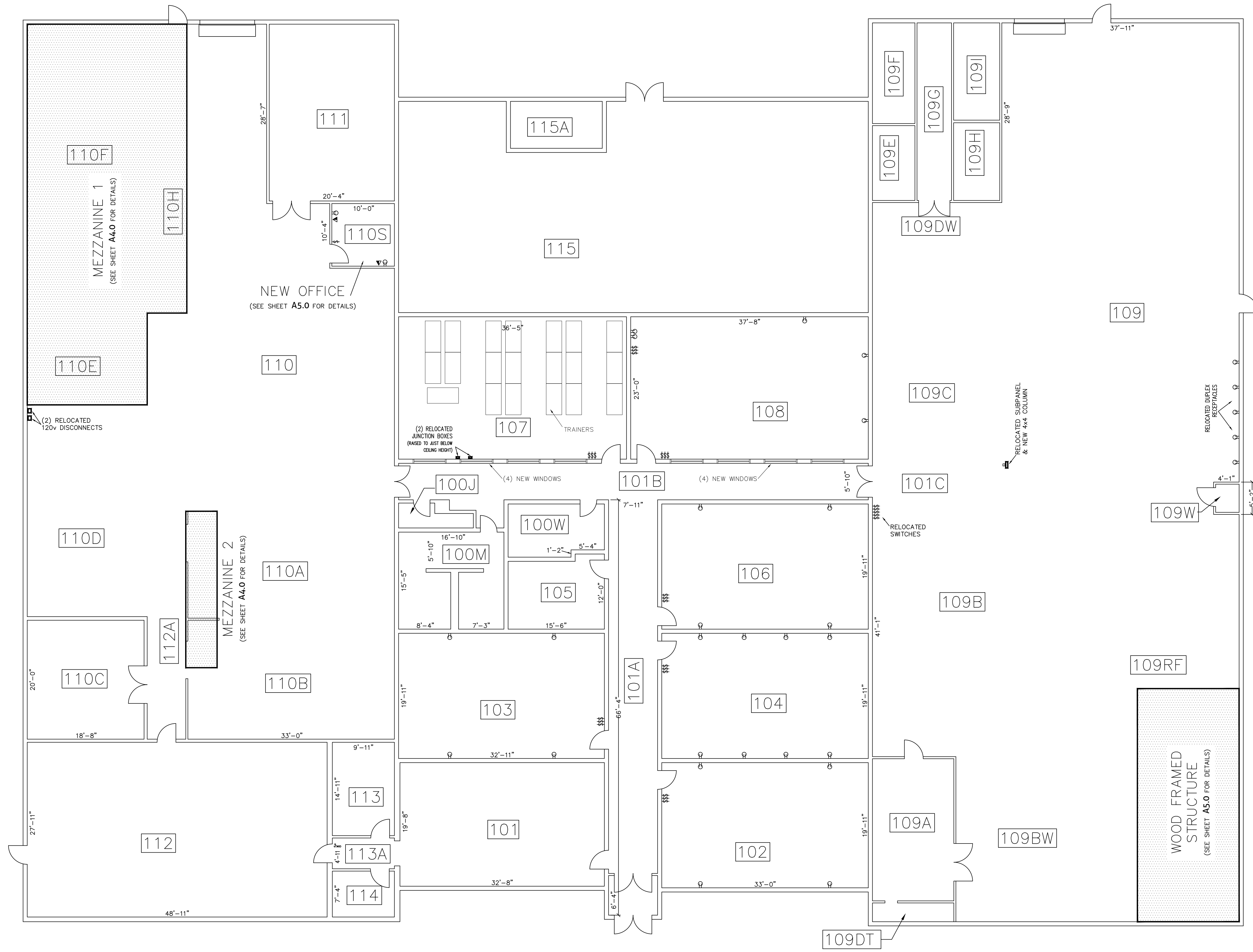

NO.	DATE	DESCRIPTION	BY



COPYRIGHT 2019 Texas State Technical College (TSTC)
 All rights reserved. No part of this publication may be reproduced by photocopying, recording, or by any other means, nor reused or modified by any means for reuse on any project other than originally intended without the prior written permission of TSTC.

Proposed ACT Renovations for
TSTC WACO
 3801 Campus Dr. Waco, TX 76705

Proposed Floor Plan
 SCALE: 1/8" = 1'-0"
 JOB NO:
 DRAWN BY: M. Schumacher
 DATE: 04/23/2019
 SHEET
A2.0
 OF 5

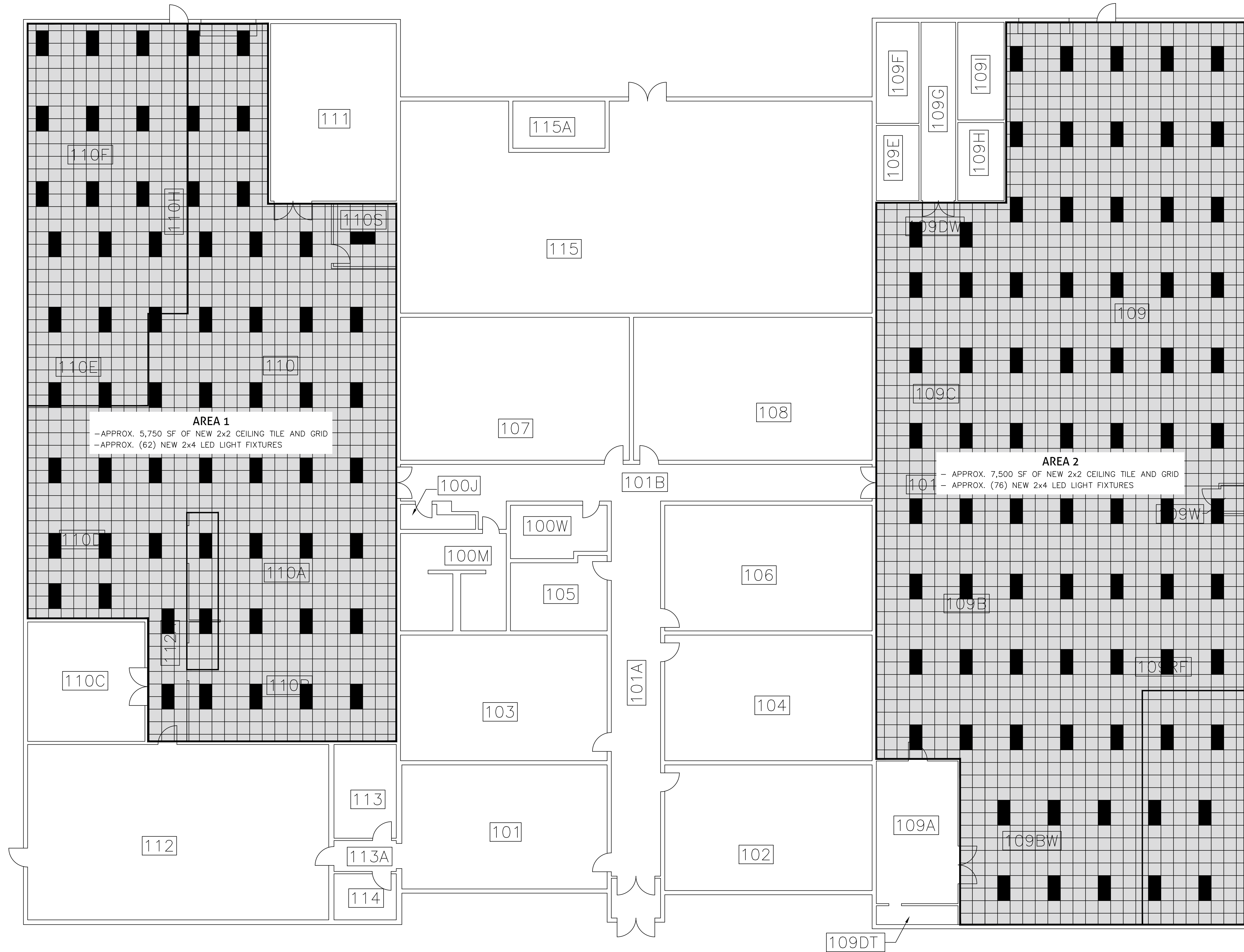

AREA 1
 - APPROX. 5,750 SF OF NEW 2x2 CEILING TILE AND GRID
 - APPROX. (62) NEW 2x4 LED LIGHT FIXTURES

AREA 2
 - APPROX. 7,500 SF OF NEW 2x2 CEILING TILE AND GRID
 - APPROX. (76) NEW 2x4 LED LIGHT FIXTURES

NO.	DATE	DESCRIPTION	BY



COPYRIGHT 2019 Texas State Technical College (TSTC)
 All rights reserved. No part of this publication may be reproduced by photocopying, recording, or by any other means, nor reused or modified by any means for reuse on any project other than originally intended without the prior written permission of TSTC.

Proposed ACT Renovations for
TSTC WACO
 3801 Campus Dr. Waco, TX 76705

Ceiling Plan
 SCALE: 1/8" = 1'-0"
 JOB NO:
 DRAWN BY: M. Schumacher
 DATE: 04/23/2019

SHEET
A3.0
 OF 5

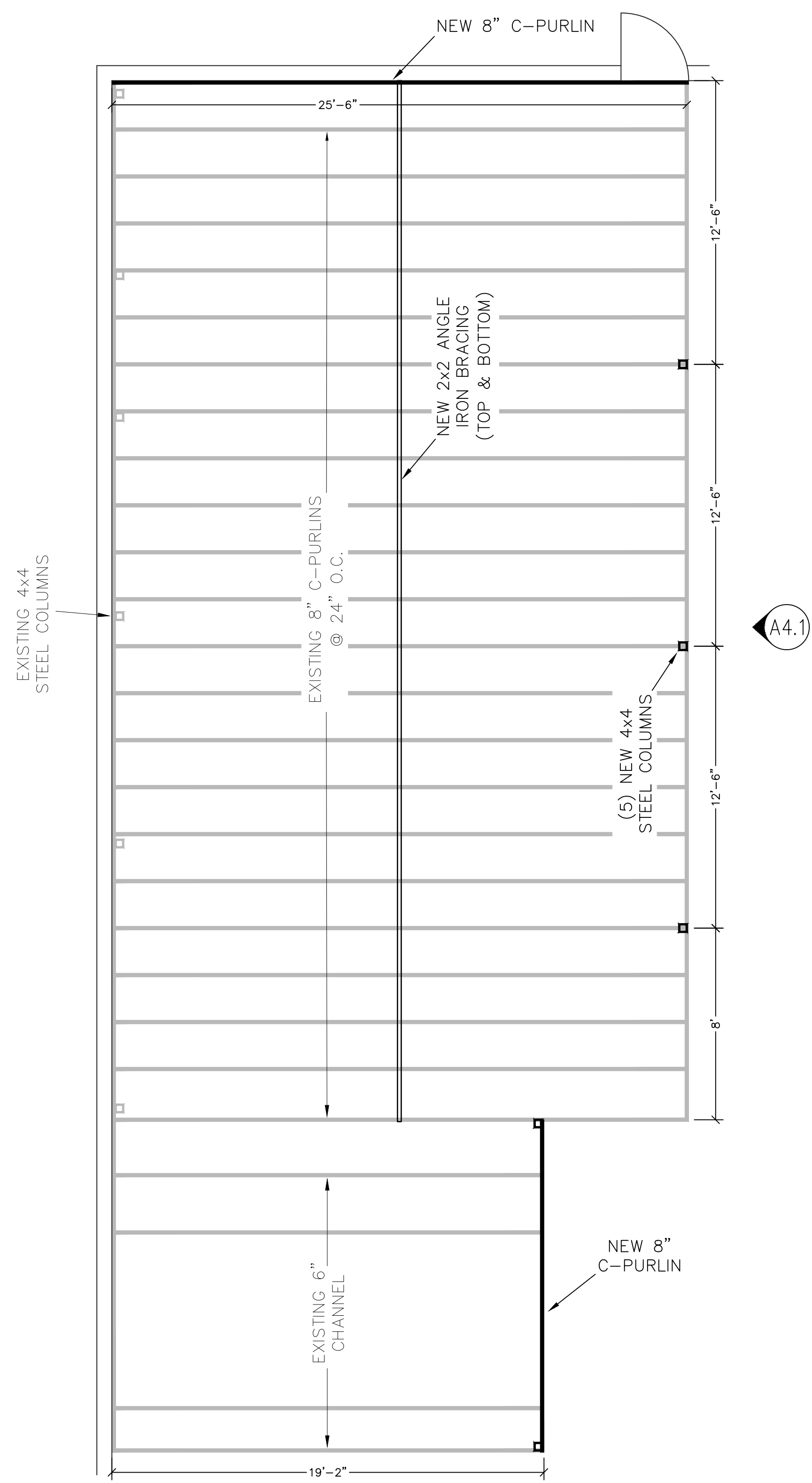

A4.1 MEZZANINE 1 - EXISTING AND NEW STEEL
SCALE: 1/4" = 1'-0"

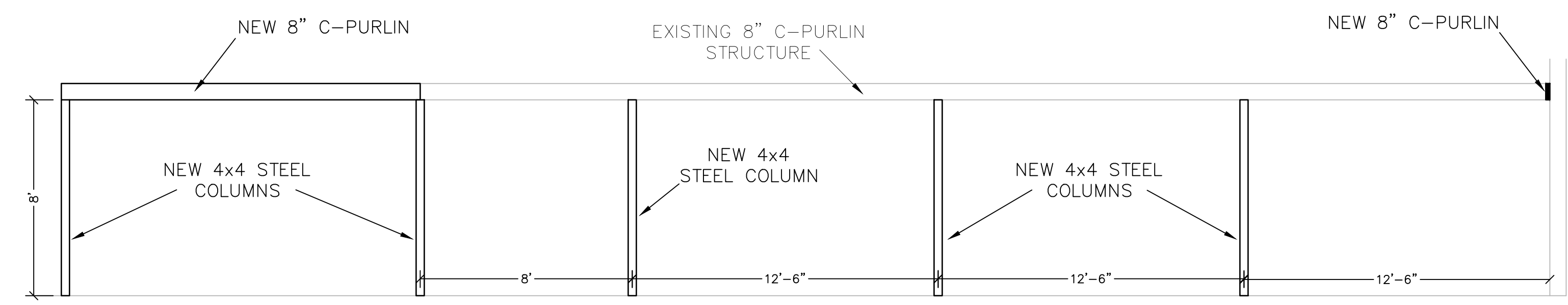

A4.1 MEZZANINE 1 - EXISTING AND NEW STEEL
SCALE: 1/4" = 1'-0"

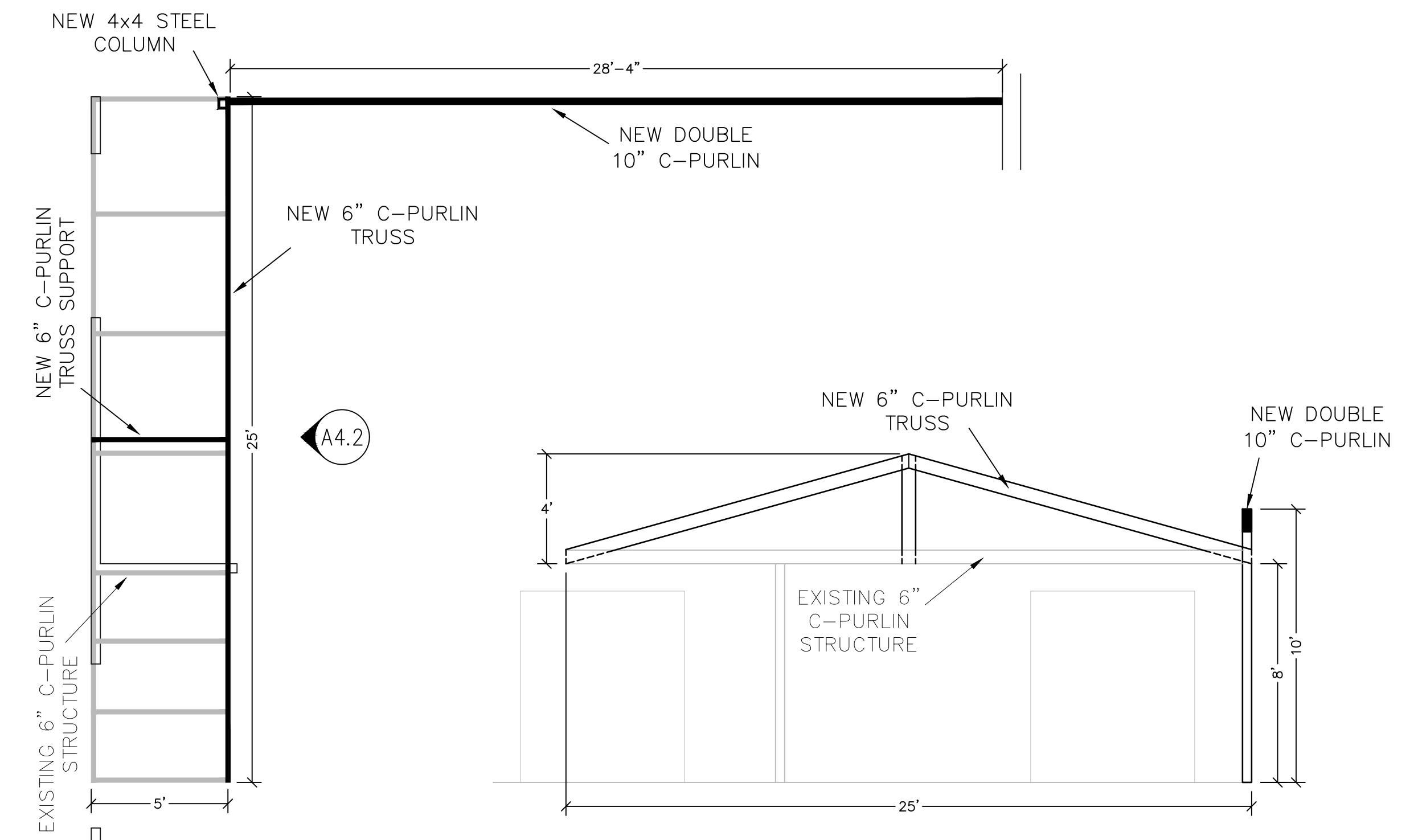

A4.2 MEZZANINE 2 - EXISTING AND NEW STEEL
SCALE: 1/4" = 1'-0"

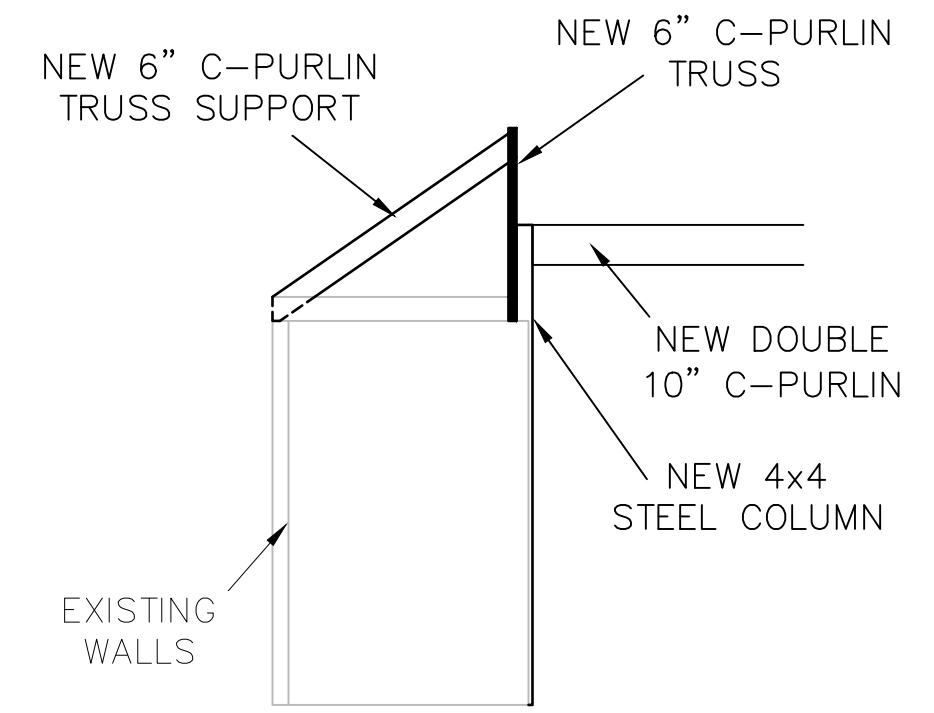

A4.3 MEZZANINE 2 - TRUSS SUPPORT
SCALE: 1/4" = 1'-0"

NO.	DATE	DESCRIPTION	BY



COPYRIGHT 2019 Texas State Technical College (TSTC)
All rights reserved. No part of this publication may be reproduced by photocopying, recording, or by any other means, nor used or modified in any manner for reuse on any project other than originally intended without the prior written permission of TSTC.

Proposed ACT Renovations for
TSTC WACO
3801 Campus Dr. Waco, TX 76705

Mezzanine Details
SCALE: 1/4" = 1'-0"
JOB NO:
DRAWN BY: M. Schumacher
DATE: 04/23/2019

SHEET
A4.0
OF 5

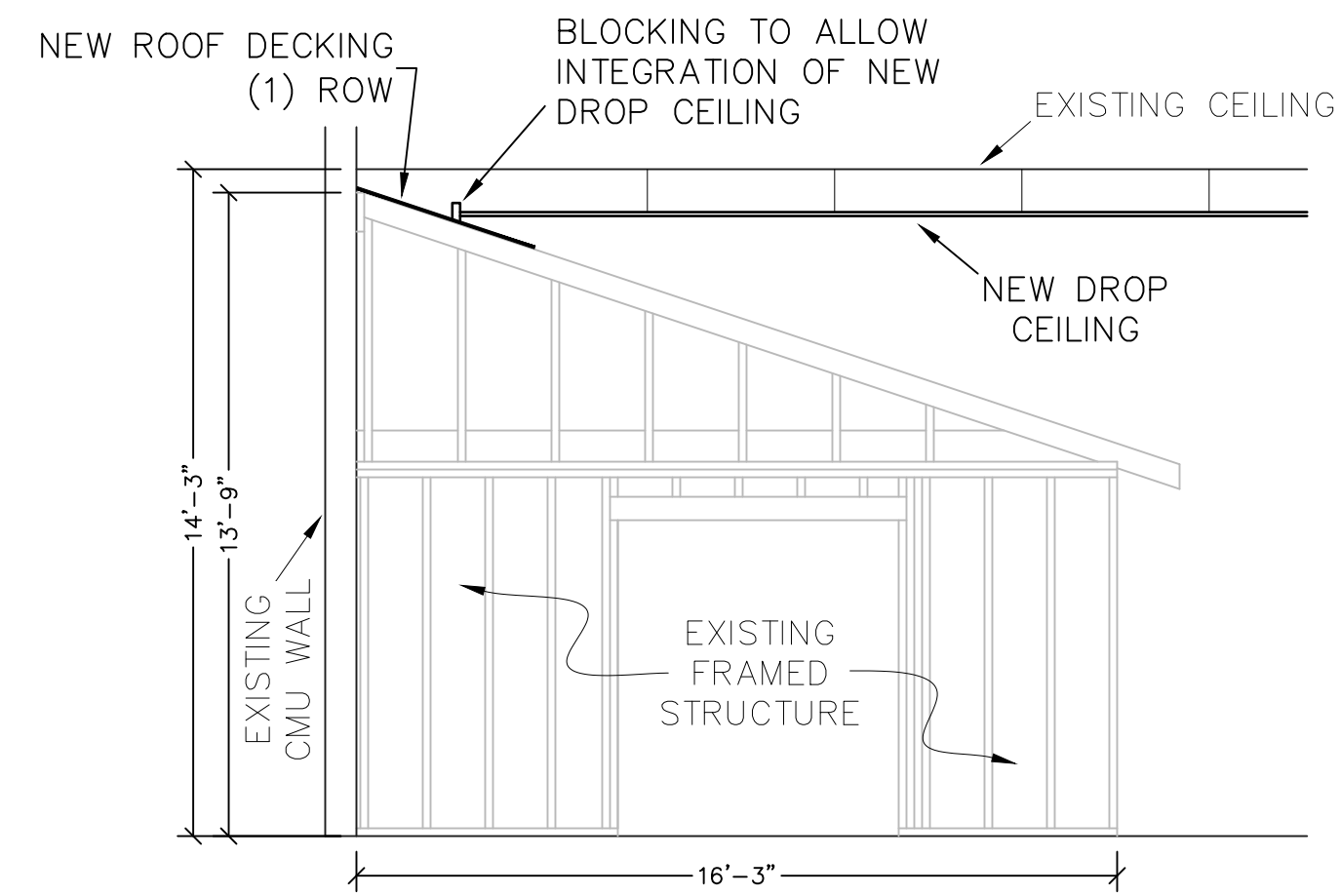
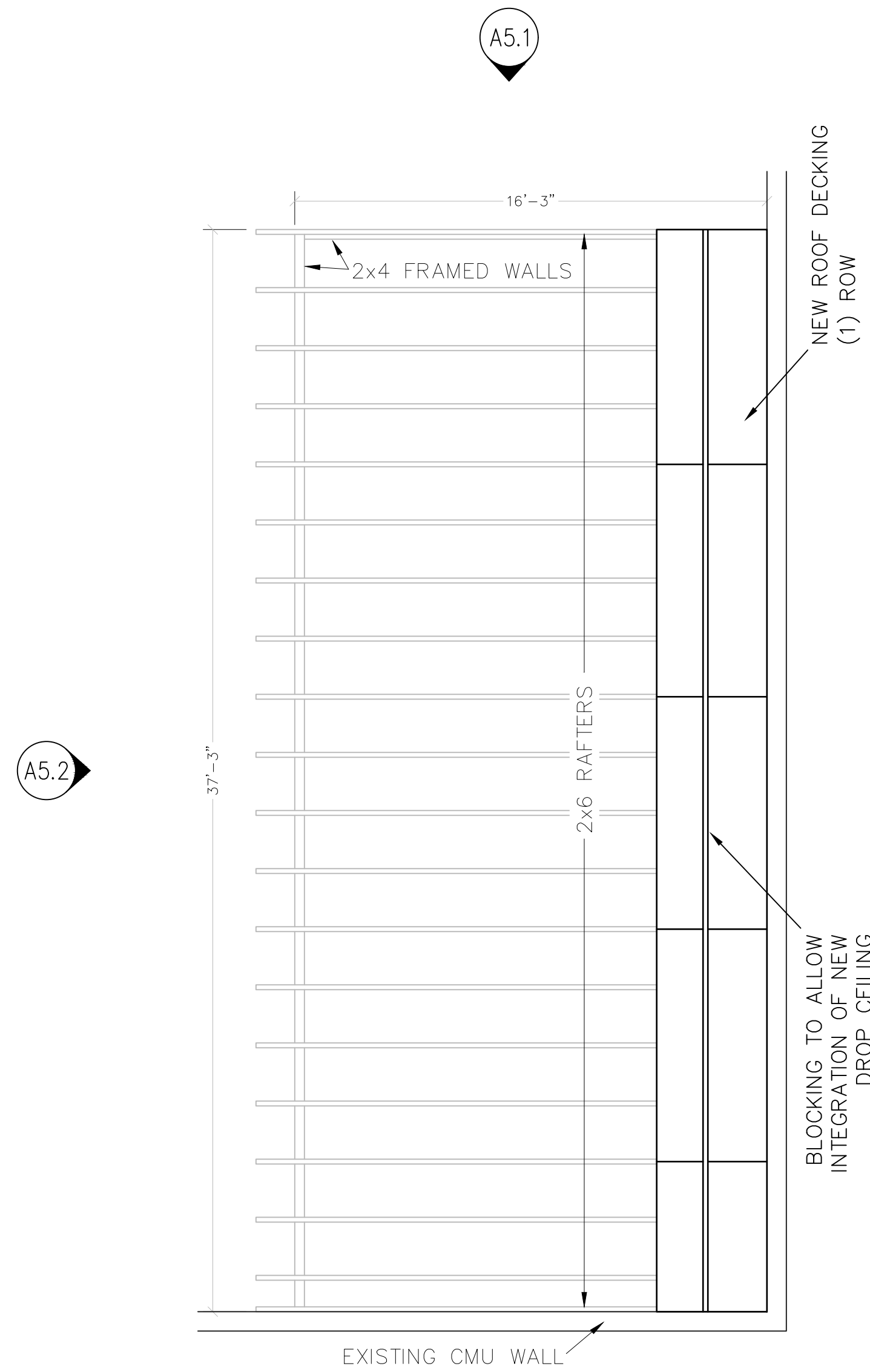

A5.1 FRAMED STRUCTURE INTEGRATION WITH DROP CEILING
SCALE: 1/4" = 1'-0"

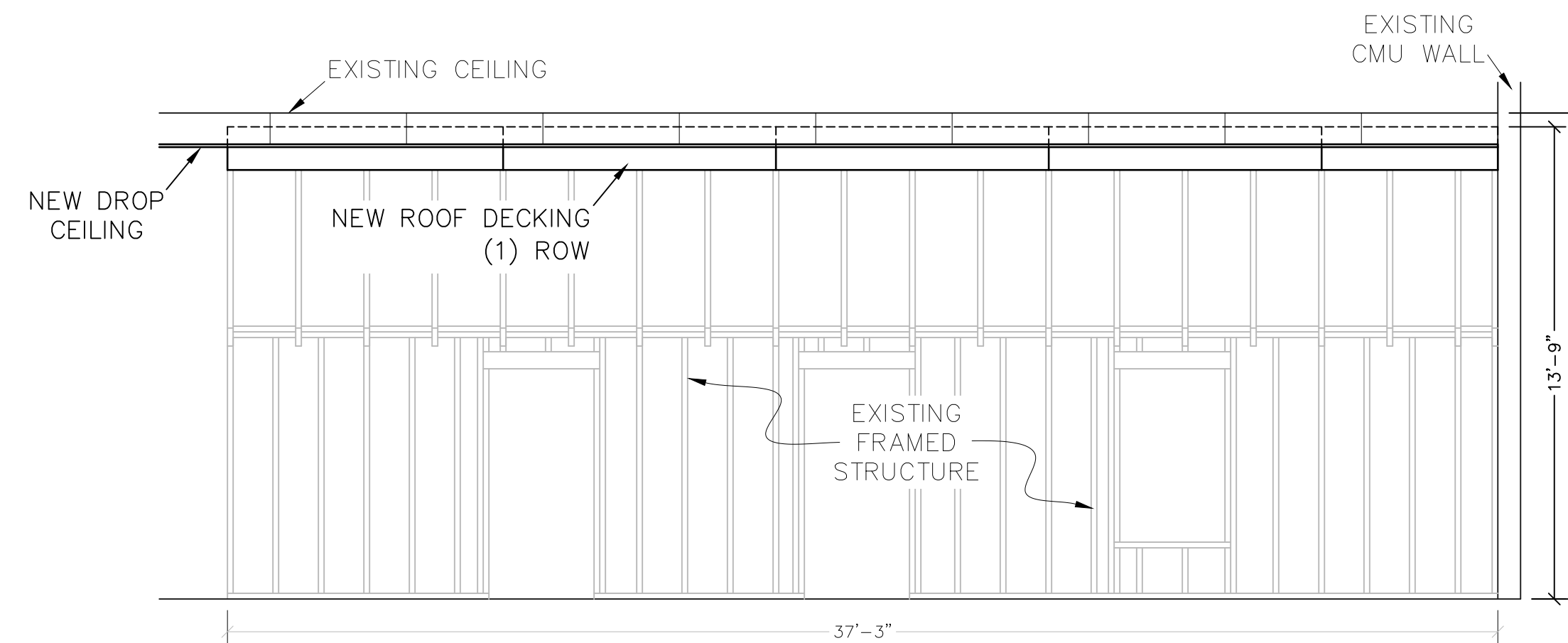

A5.2 FRAMED STRUCTURE INTEGRATION WITH DROP CEILING
SCALE: 1/4" = 1'-0"

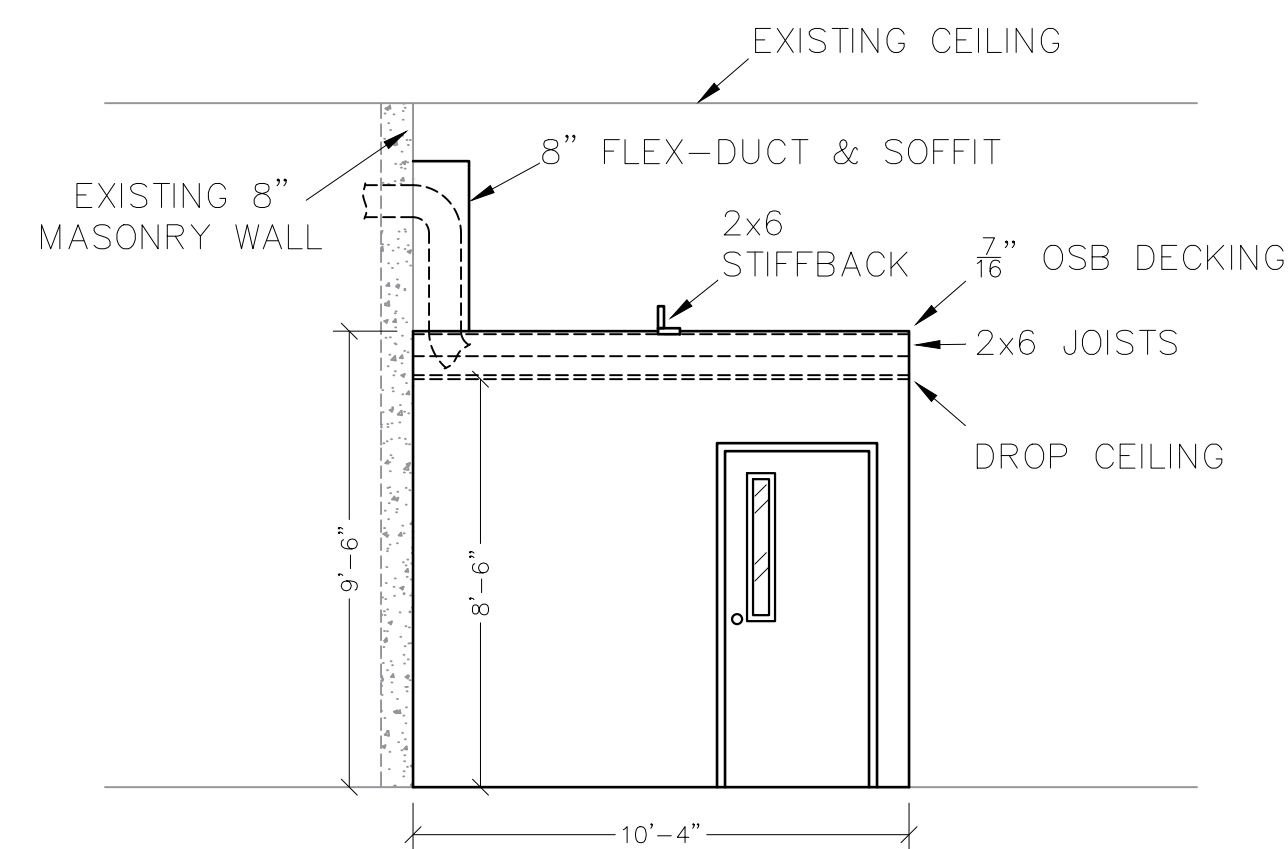
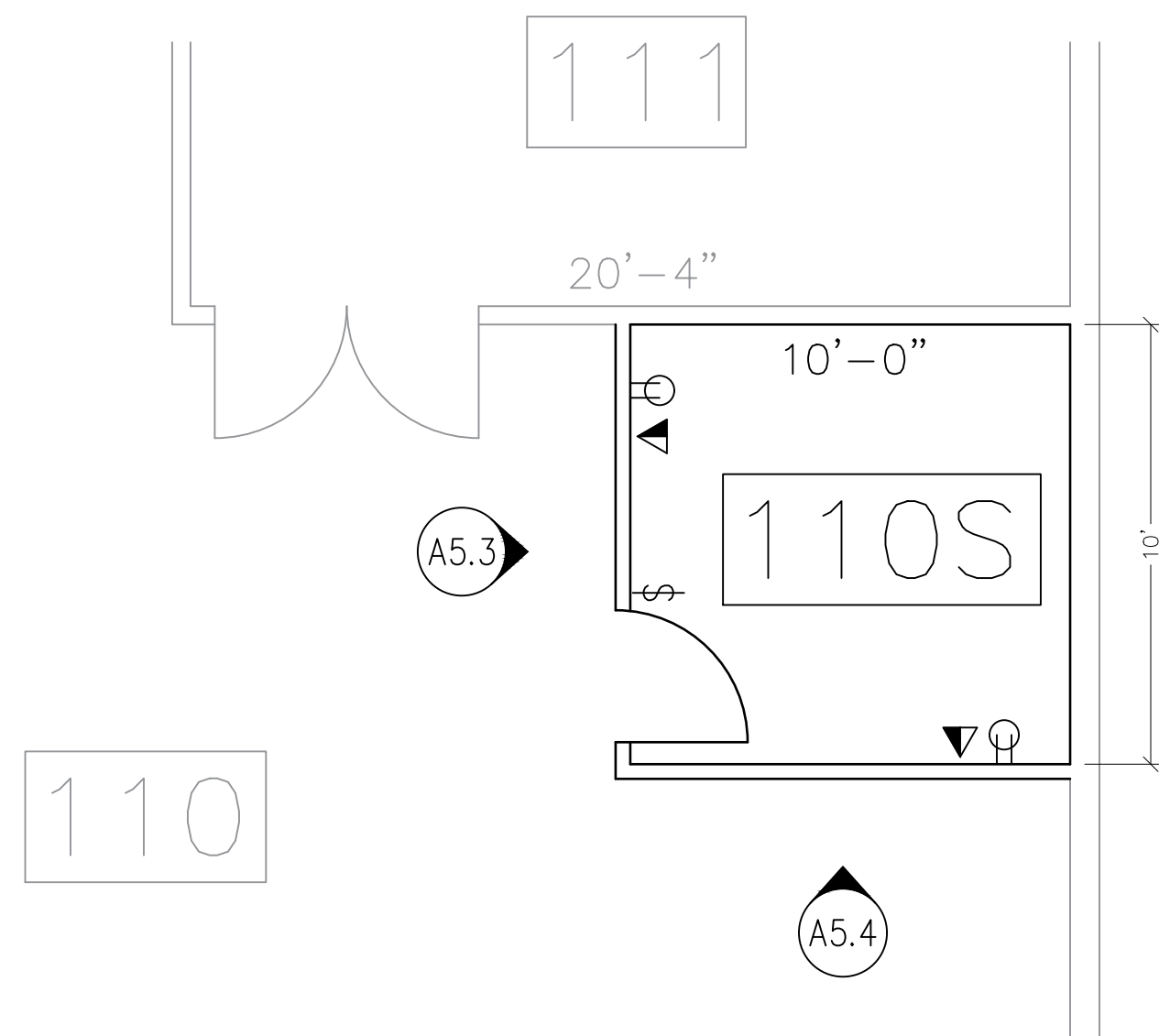

A5.3 NEW OFFICE ELEVATION 1
SCALE: 1/4" = 1'-0"

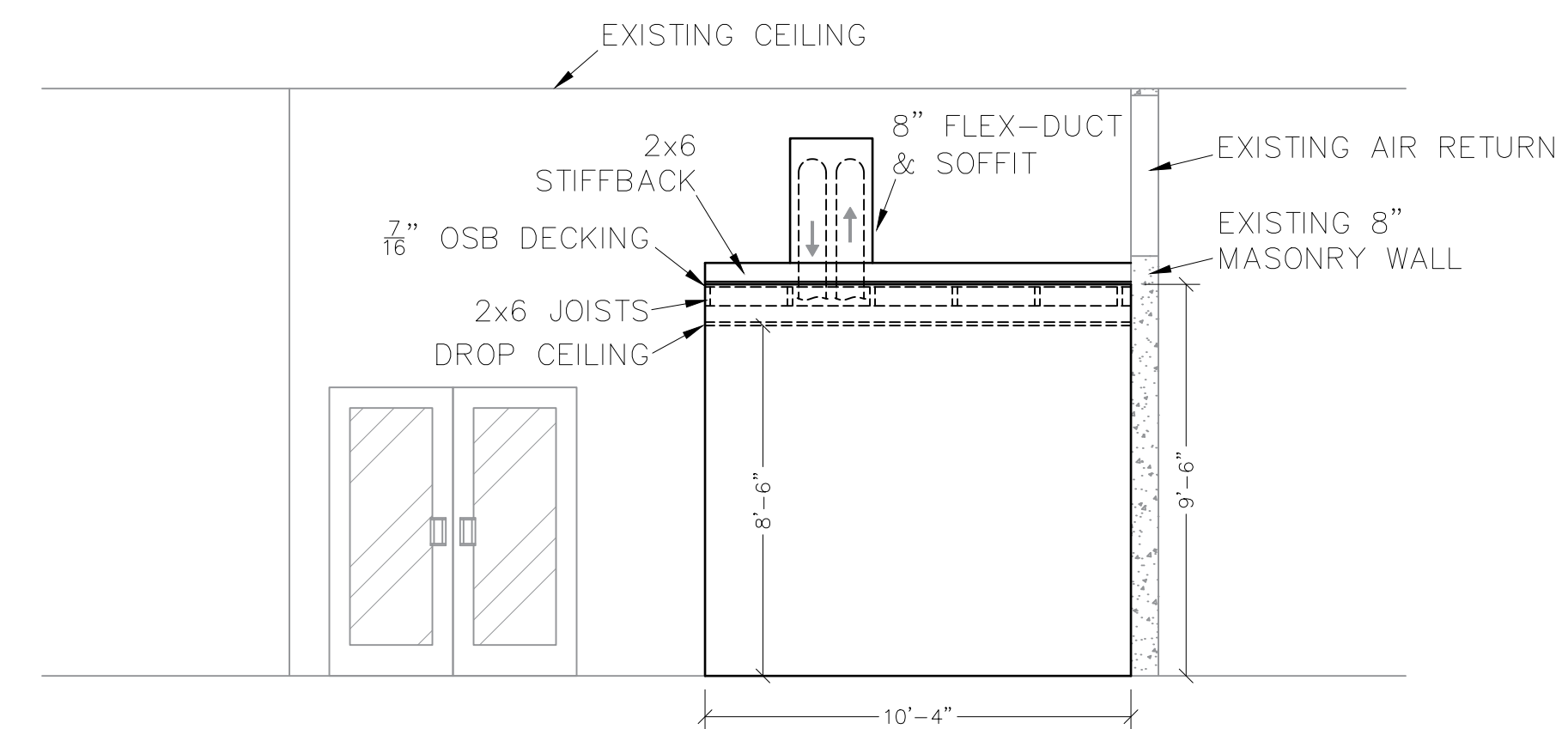

A5.4 NEW OFFICE ELEVATION 2
SCALE: 1/4" = 1'-0"



Copyright 2019 Texas State Technical College (TSTC)
All rights reserved. No part of this publication may be reproduced by photocopying, recording, or by any other means, nor reused or modified by any means for reuse on any project other than originally intended without the prior written permission of TSTC

Proposed ACT Renovations for
TSTC WACO
3801 Campus Dr. Waco, TX 76705

Additional Details
SCALE: 1/4" = 1'-0"
JOB NO:
DRAWN BY: M. Schumacher
DATE: 04/23/2019

SHEET
A5.0
OF 5

NO.	DATE	DESCRIPTION	BY

TSTC Waco PBE Renovations for ACT

Work Schedule

Do to the ACT building's nature as an educational facility, it is necessary to accommodate the class/lab schedule when planning and executing different elements of construction work in different areas of the building. While this document is not intended to serve as an exhaustive description of student and faculty activity in the ACT building, it is intended to provide an overview of the typical ongoing schedule maintained by the building's tenants during the summer semester. Contractors and/or TSTC instructors may request special scheduling accommodations for necessary work at any time. TSTC Project Managers will do everything in their power to coordinate such accommodations as they arise.

(SEE SCHEDULE & ZONING MAP ON NEXT PAGE)

TSTC Waco PBE Renovations for ACT

Work Schedule (continued)

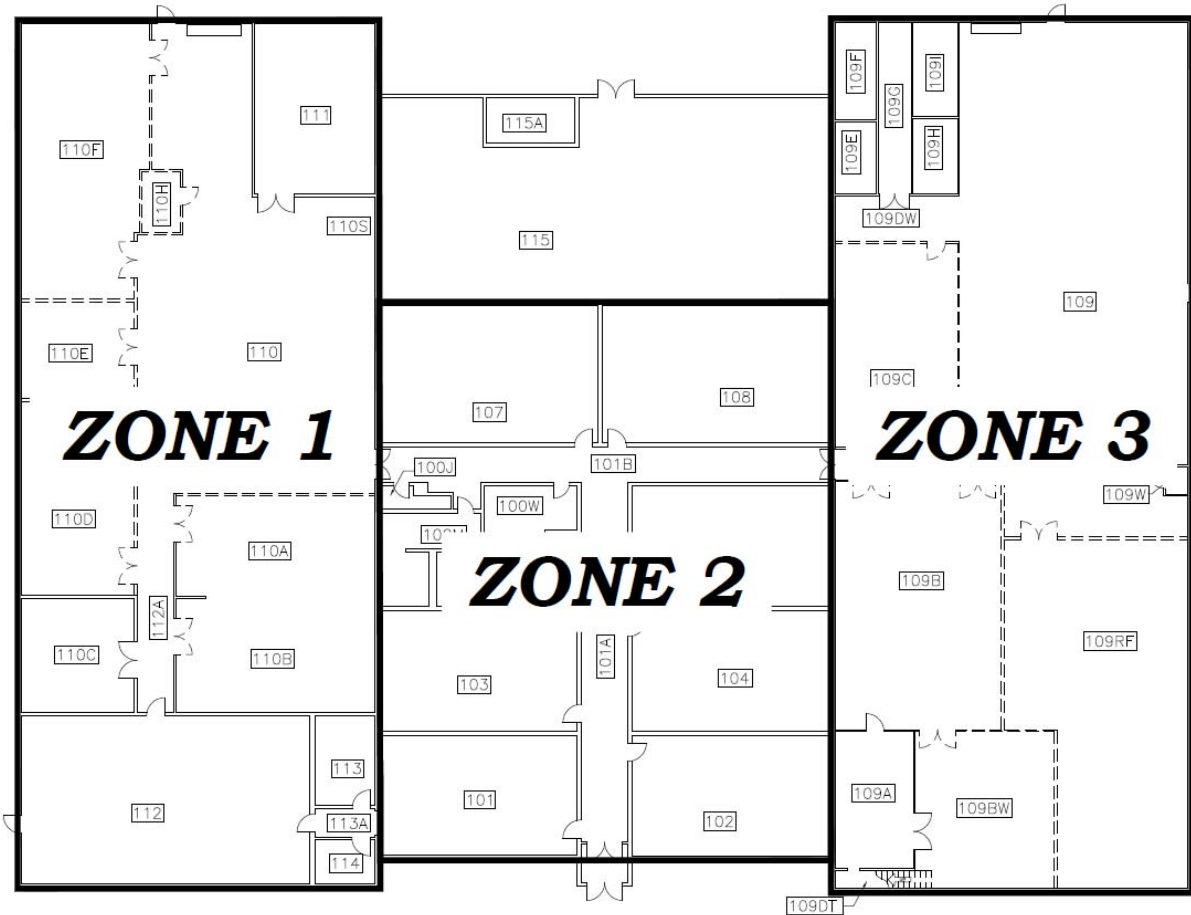

	ZONE 1		ZONE 2		ZONE 3	
	am	pm	am	pm	am	pm
Mon	X	X	X	X	✓	✓
Tue	X	X	✓	X	X	X
Wed	X	X	X	X	✓	✓
Thu	X	X	✓	X	X	X
Fri	✓	✓	✓	✓	✓	✓
Sat	✓	✓	✓	✓	✓	✓
Sun	✓	✓	✓	✓	✓	✓

X = Area not available for work during this period
✓ = Area not available for work during this period